



**ENGINEERING REPORT  
PREPARED FOR**

Barrette Outdoor Living

2401 Corporate Boulevard, Brooksville, FL 34604

**CALCULATIONS FOR FULL AND HALF PRIVACY RAILING  
WITH PLATED POSTS-SCREWBOSSES  
IBC 2018 AND IRC 2018**

**Jacek Sluzynski, PE  
8/25/2021**

Seals

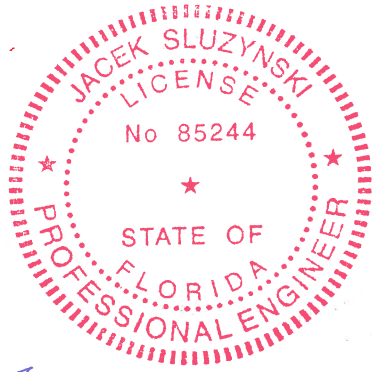

Jacek Sluzynski  
8/27/2021



Jacek Sluzynski  
8/27/2021

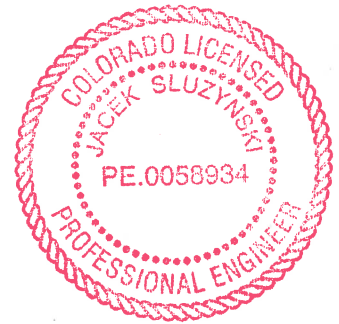

Jacek Sluzynski  
8/27/2021

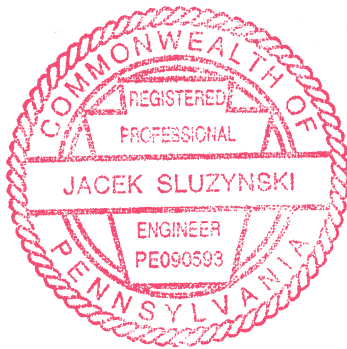

Jacek Sluzynski  
8/27/2021

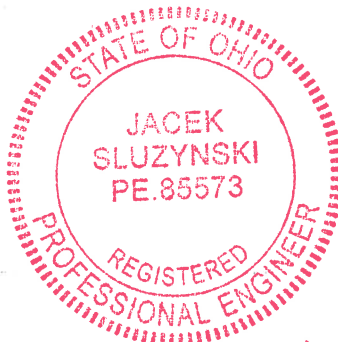

Jacek Sluzynski  
8/27/2021



Jacek Sluzynski  
8/27/2021



Jacek Sluzynski  
8/27/2021



Jacek Sluzynski  
8/27/2021



Jacek Sluzynski  
8/27/2021

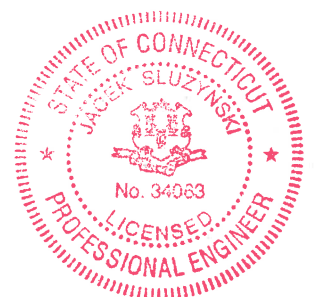

Jacek Sluzynski  
8/27/2021

Seals

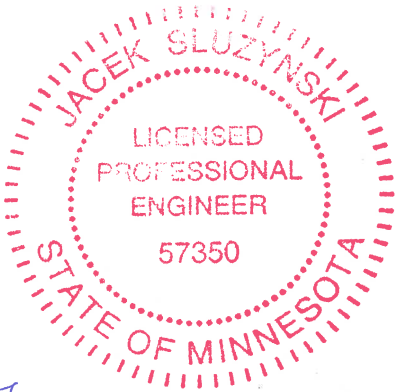

*Jacek Sluzynski*  
*8/27/2021*

I hereby certify that this plan, specification, or report was prepared by me or under my direct supervision and that I am a duly Licensed Professional Engineer under the laws of the state of Minnesota.

Signature: *Jacek Sluzynski*

Typed or Printed Name: JACEK SLUZYSKI

Date: 8/27/2021 License Number: 57350

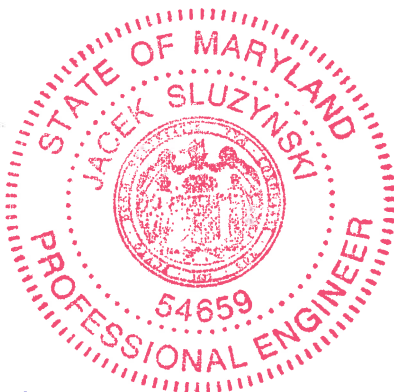

*Jacek Sluzynski*  
*8/27/2021*

Professional Certification. I hereby certify that these documents were prepared or approved by me, and that I am a duly licensed professional engineer under the laws of the State of Maryland. License No. 54659 Expiration Date: 7/11/2023.

*Jacek Sluzynski*  
*8/27/2021*

**I. INTRODUCTION.**

- THE PURPOSE OF THIS REPORT IS TO EVALUATE HALF PRIVACY AND FULL PRIVACY PANEL FOR WIND RESILIENCE AND RAILING LOADS
- EVALUATION WILL BE LIMITED TO 42’’ MAX. HIGH FOR HALF PRIVACY AND TO 72’’ MAX. HIGH FOR FULL PRIVACY
- EVALUATION WILL BE LIMITED TO 72’’ MAX. WIDTH FOR HALF PRIVACY AND TO 72’’ MAX. WIDTH FOR FULL PRIVACY
- POST AND RAILS WILL BE EVALUATED BASED ON THEIR RESILIENCE TO BENDING MOMENT
- MATERIAL:
  - 6005-T5 – POSTS, RAILS & PLATES (  $F_{ty} = 34.8$  ksi )
  - PVC– INFILL SLATS ( $F_{ty} = 6.2$  ksi)
- POSTS WILL BE PLATED ON THE GROUND LEVEL ON CONCRETE OR DECK

**FOR APPLICATION EXPOSED TO THE WIND:**

- RISK CATEGORY STRUCTURE - II
- EXPOSURE – B,C&D ANALIZED ( SEE TABLE p.16-18)
- HEIGHT LESS THAN 15FT ABOVE GROUND
- THE WIND DESIGN FOR SOLID SIGNS PERFORMEND
- WIND SPEED :  
ASCE 7-16 MAP - 115MPH TO 140MPH FOR VIRGINIA, MARYLAND,  
PENNSYLVANIA, CONNECTICUT, MASSACHUSSETTS & NEW JERSEY.

## II. GEOMETRIC PROPERTIES OF RAILS, POSTS & INFILLS

- Section properties of the selected face of TOP RAIL EPN-0559

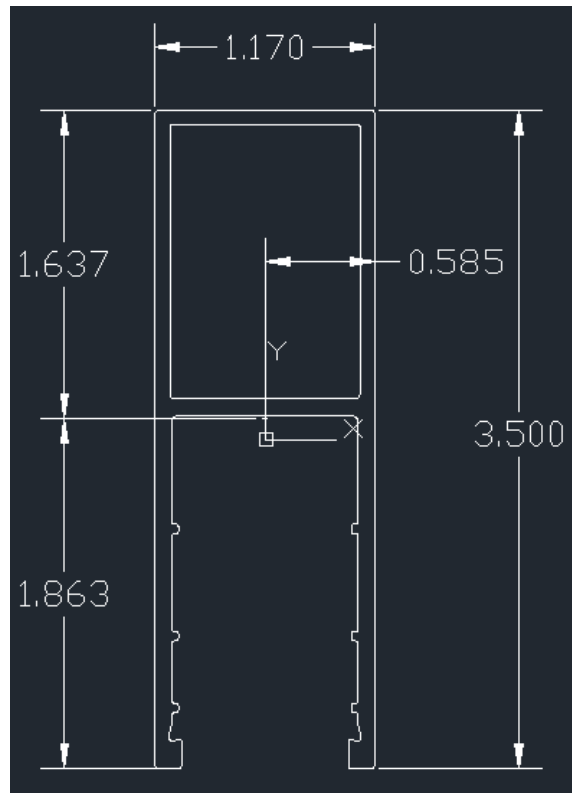
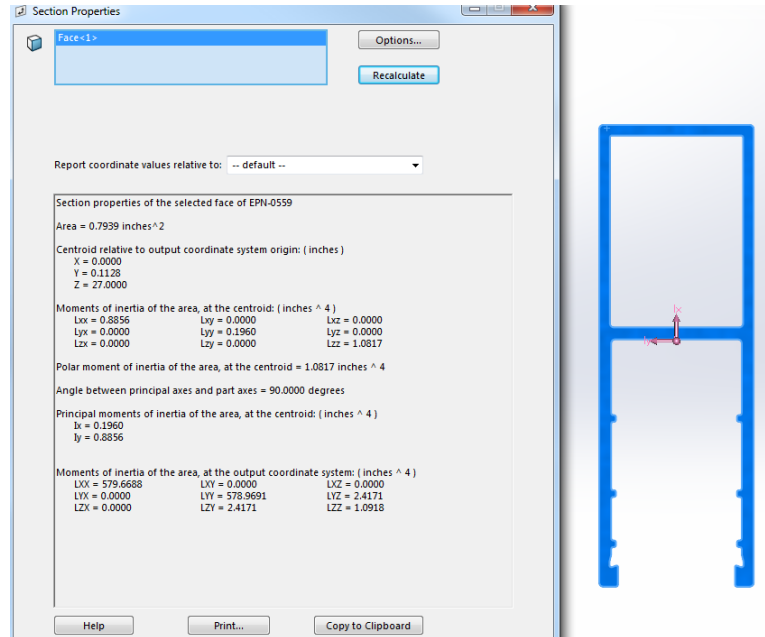

Section Modulus:

$$S_x = I_x / C_x = 0.1960 / (0.585) = 0.335 \text{ in}^3$$

$$S_y = I_y / C_y = 0.8856 / (1.863) = 0.475 \text{ in}^3$$

➤ Section properties of the selected face of MID RAIL EPN-0670

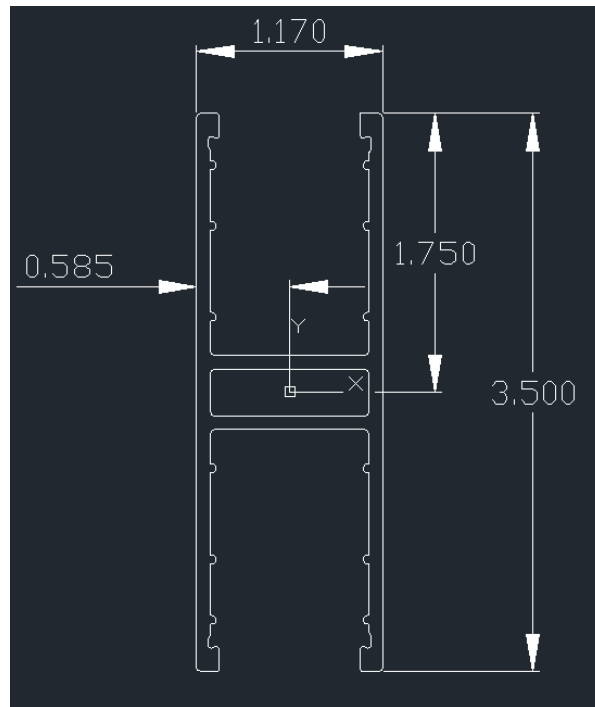
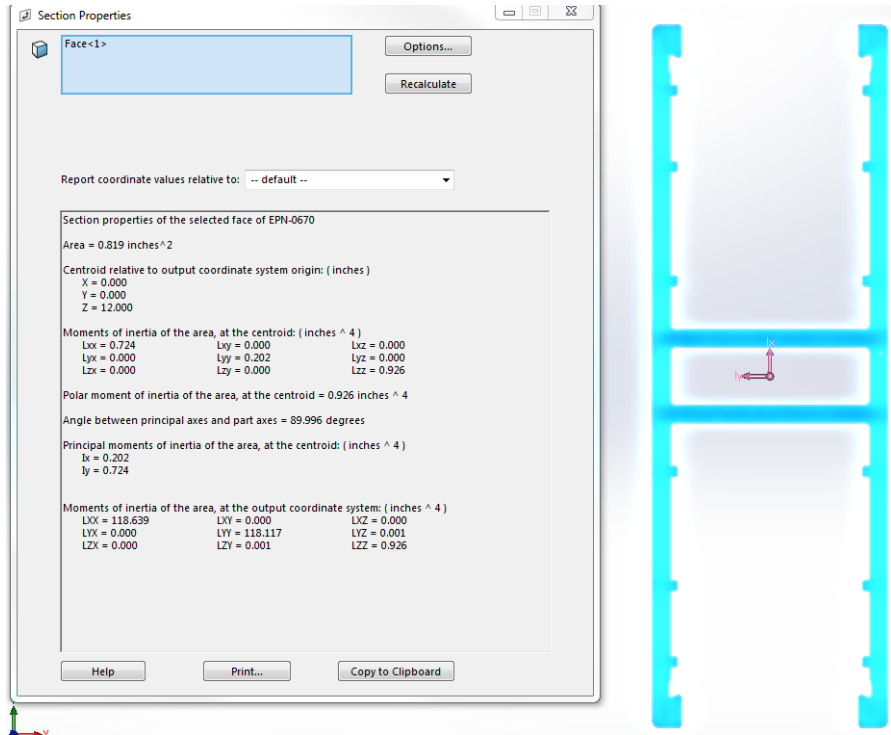

Section Modulus:

$$S_x = I_x / C_x = 0.2020 / (0.585) = 0.345 \text{ in}^3$$

$$S_y = I_y / C_y = 0.724 / (1.750) = 0.414 \text{ in}^3$$

➤ Section properties of the selected face of END POST **EPN-0667**

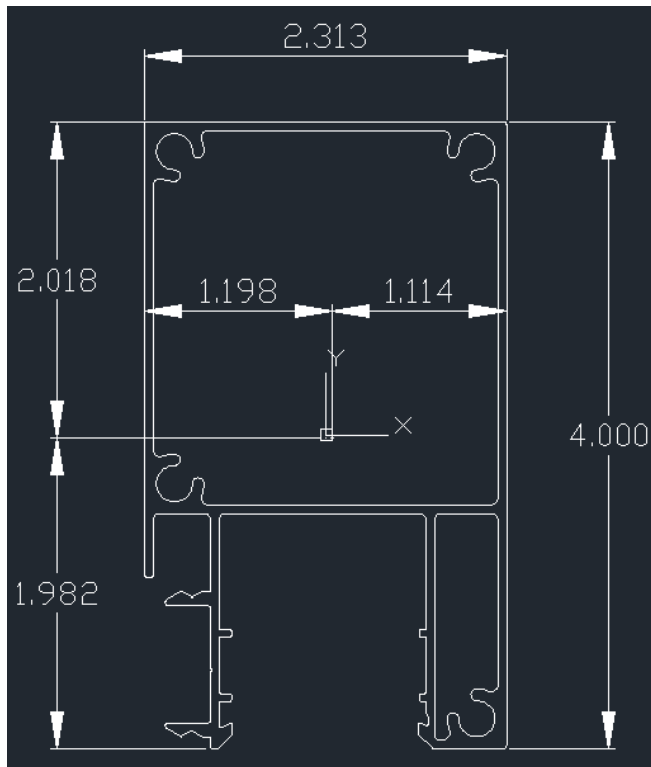
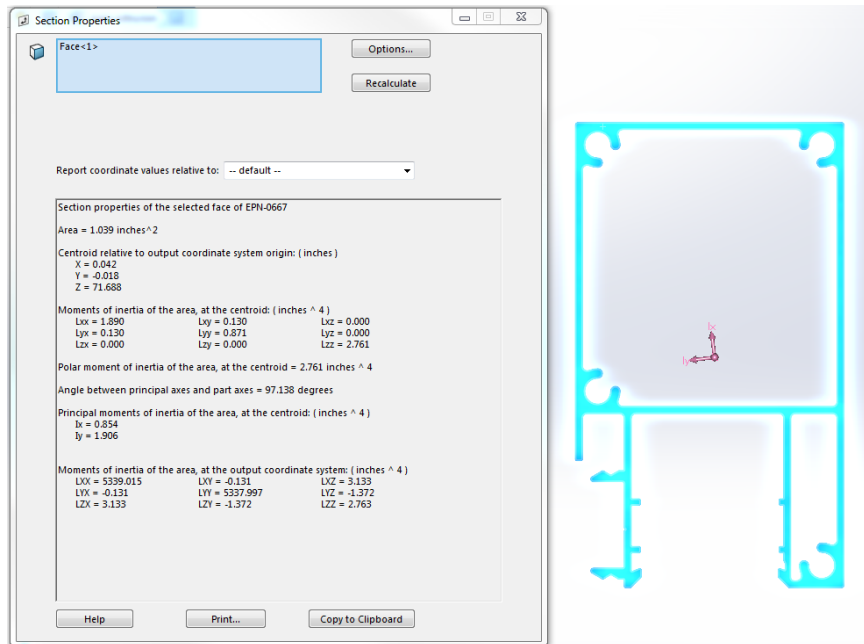

Section Modulus:

$$S_x = I_x / C_x = 0.854 / (1.198) = 0.713 \text{ in}^3$$

$$S_y = I_y / C_y = 1.906 / (2.18) = 0.874 \text{ in}^3$$

➤ Section properties of the selected face of LINE POST **EPN-0669**

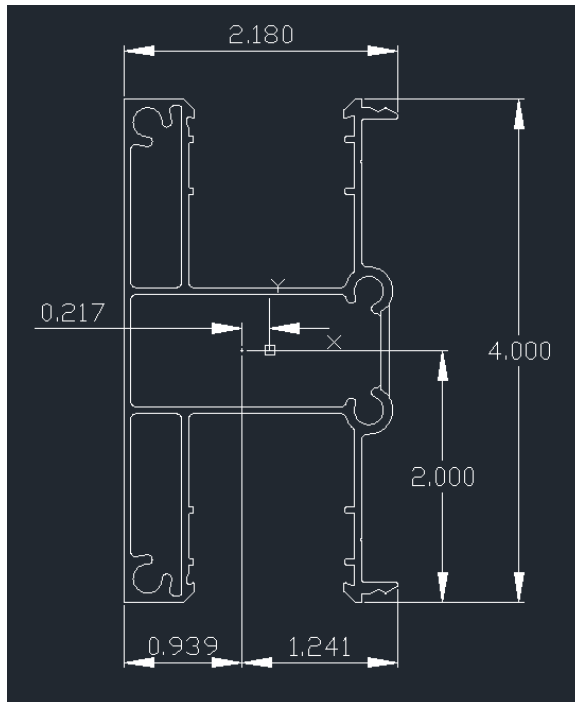
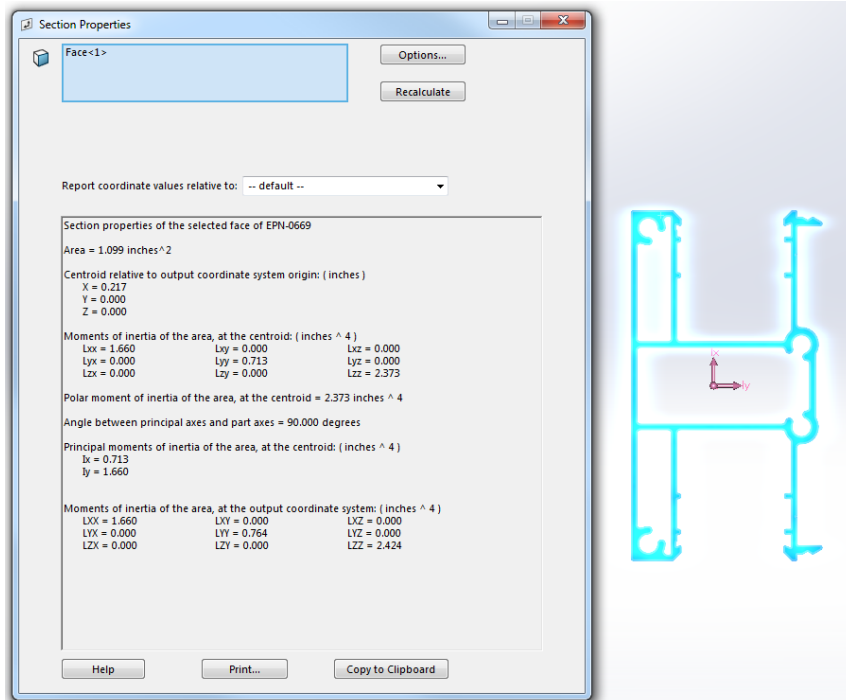

Section Modulus:

$$S_x = I_x / C_x = 0.713 / (1.241) = 0.575 \text{ in}^3$$

$$S_y = I_y / C_y = 1.660 / (2.000) = 0.830 \text{ in}^3$$

➤ Section properties of the selected face of CORNER POST **EPN-0668**

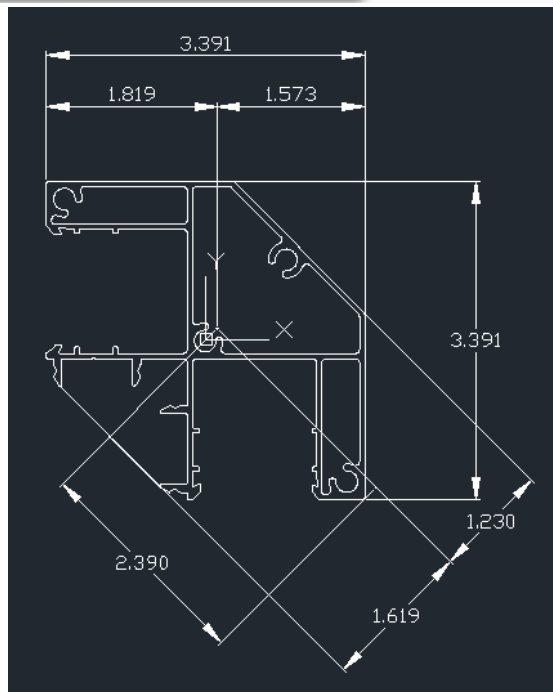
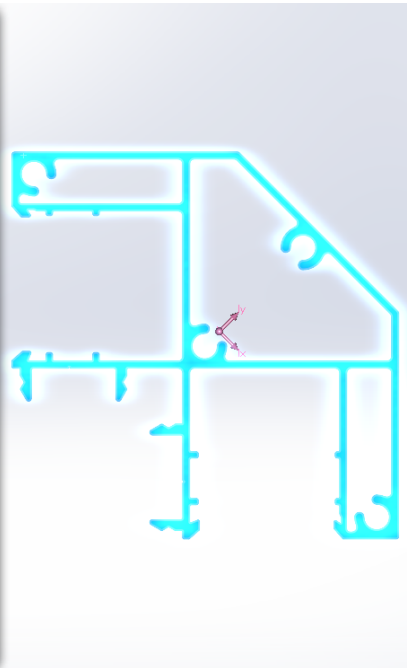
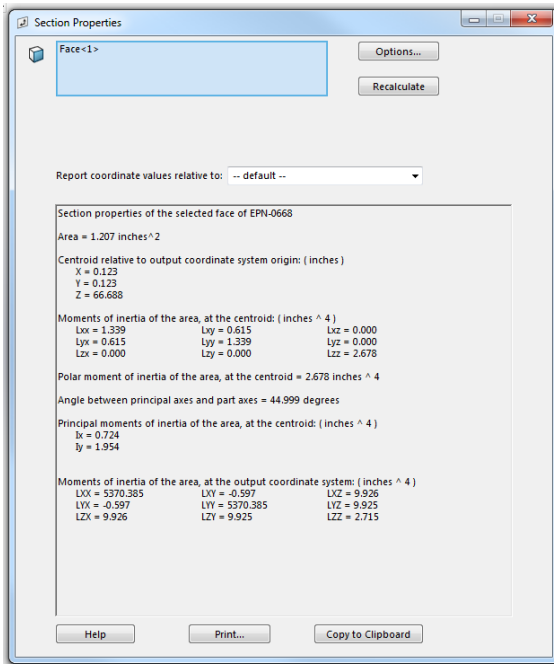

Section Modulus-based on principal Moment of Inertia:

$$S_x = I_x / C_x = 0.724 / (1.619) = 0.447 \text{ in}^3$$

$$S_y = I_y / C_y = 1.954 / (2.39) = 0.818 \text{ in}^3$$

Section Modulus- Moment of the Inertia at the centroid parallel to coordinate system:

$$S_x = I_x / C_x = 1.339 / (1.819) = 0.736 \text{ in}^3$$

$$S_y = I_y / C_y = 1.339 / (1.819) = 0.736 \text{ in}^3$$

➤ Section properties of the selected face of HORIZONTAL INFILL 61106640

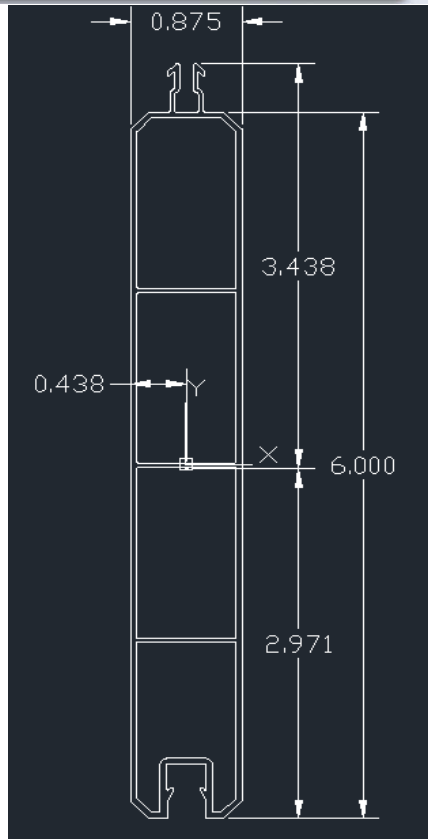
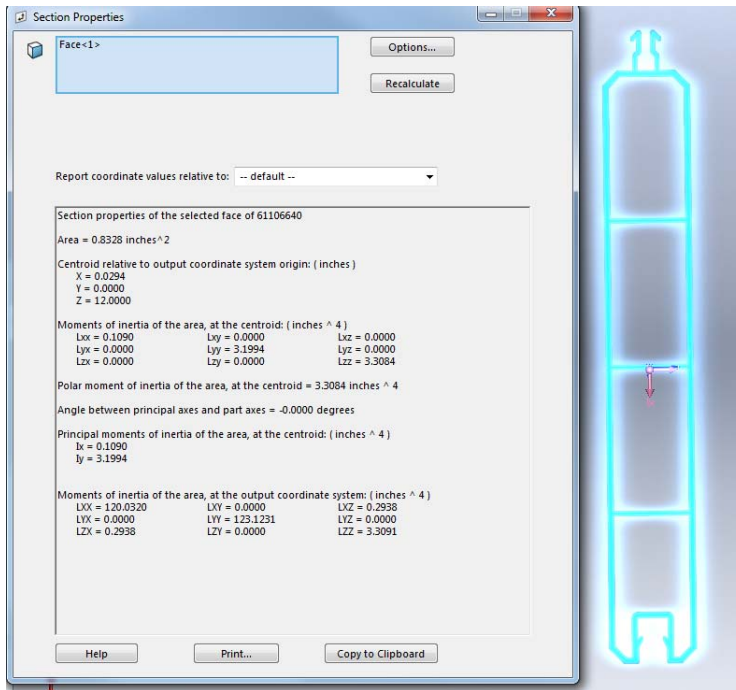

Section Modulus:

$$S_x = I_x / C_x = 0.1090 / (0.438) = 0.249 \text{ in}^3$$

$$S_y = I_y / C_y = 3.1994 / (3.438) = 0.931 \text{ in}^3$$

### III. RESISTING MOMENT CALCULATION RAILS, POSTS & INFILLS

#### Elastic modulus

$$S = I/y \text{ (in}^3\text{)}$$

S – Elastic modulus

y – Distance from the neutral axis

#### Resisting Moment (yield Moment)

$$M = S * \sigma \text{ (kip-in)}$$

S – Elastic modulus

$\sigma$  – Yield strength

- TOP RAIL EPN-0559

$$S_x = I_x / C_x = 0.1960 \text{ in}^4 / 0.585 \text{ in} = 0.335 \text{ in}^3$$

$$S_y = I_y / C_y = 0.8856 \text{ in}^4 / 1.863 \text{ in} = 0.475 \text{ in}^3$$

$$M_x = 34.8 \text{ ksi} * 0.335 \text{ in}^3 = 11.66 \text{ kip-in} = 972 \text{ lb-ft}$$

$$M_y = 34.8 \text{ ksi} * 0.475 \text{ in}^3 = 16.53 \text{ kip-in} = 1378 \text{ lb-ft}$$

For 200lbs point load applied horizontally:

$$M = PL/4 = (200\text{lb} * 68\text{in}/12)/4 = 283\text{lb-ft}$$

$$M_x/M = SF$$

$$972 \text{ lb-ft}/283\text{lb-ft} = 3.43 > 1.67 \rightarrow \text{design OK}$$

For 50lbs distributed load applied horizontally:

$$M = wl^2/8 = (50\text{lb} * (68\text{in}/12)^2)/8 = 201\text{lb-ft}$$

$$M_x/M = SF$$

$$972 \text{ lb-ft}/201\text{lb-ft} = 4.83 > 1.67 \rightarrow \text{design OK}$$

- MID RAIL EPN-0670

$$S_x = I_x / C_x = 0.2020 \text{ in}^4 / 0.585 \text{ in} = 0.345 \text{ in}^3$$

$$S_y = I_y / C_y = 0.724 \text{ in}^4 / 1.750 \text{ in} = 0.414 \text{ in}^3$$

$$M_x = 34.8 \text{ ksi} * 0.345 \text{ in}^3 = 12.01 \text{ kip-in} = 1001 \text{ lb-ft}$$

$$M_y = 34.8 \text{ ksi} * 0.414 \text{ in}^3 = 14.41 \text{ kip-in} = 1201 \text{ lb-ft}$$

For 200lbs point load applied horizontally:

$$M = PL/4 = (200\text{lb} * 68\text{in}/12)/4 = 283\text{lb-ft}$$

$$M_x/M = SF$$

$$1001 \text{ lb-ft}/283\text{lb-ft} = 3.53 > 1.67 \rightarrow \text{design OK}$$

For 50lbs distributed load applied horizontally:

$$M = wl^2/8 = (50\text{lb} * (68\text{in}/12)^2)/8 = 201\text{lb-ft}$$

$$M_x/M = SF$$

$$1001 \text{ lb-ft}/201\text{lb-ft} = 4.98 > 1.67 \rightarrow \text{design OK}$$

- END POST EPN-0667

$$S_x = I_x / C_x = 0.854 \text{ in}^4 / 1.198 \text{ in} = 0.713 \text{ in}^3$$

$$S_y = I_y / C_y = 1.906 \text{ in}^4 / 2.180 \text{ in} = 0.874 \text{ in}^3$$

$$M_x = 34.8 \text{ ksi} * 0.713 \text{ in}^3 = 24.81 \text{ kip-in} = 2068 \text{ lb-ft}$$

$$M_y = 34.8 \text{ ksi} * 0.874 \text{ in}^3 = 30.42 \text{ kip-in} = 2535 \text{ lb-ft}$$

- LINE POST EPN-0669

The line post is the worst case scenario (corner and ends posts will sustain loads if line post does)

This calculation is for post fixed at the bottom (core drill or concrete footing)

$$S_x = I_x / C_x = 0.713 \text{ in}^4 / 1.241 \text{ in} = 0.575 \text{ in}^3$$

$$S_y = I_y / C_y = 1.660 \text{ in}^4 / 2.000 \text{ in} = 0.830 \text{ in}^3$$

$$M_x = 34.8 \text{ ksi} * 0.575 \text{ in}^3 = 20.01 \text{ kip-in} = 1668 \text{ lb-ft}$$

$$M_y = 34.8 \text{ ksi} * 0.830 \text{ in}^3 = 28.88 \text{ kip-in} = 2407 \text{ lb-ft}$$

For 300lbs point load applied horizontally at 3.5ft above ground (6FT WIDE PANEL):

$$M = P * L = 300 \text{ lb} * 3.5 \text{ ft} = 1050 \text{ lb-ft}$$

$$M_x / M = SF$$

$$1668 \text{ lb-ft} / 1050 \text{ lb-ft} = 1.59 \Rightarrow \text{design OK (1.50-1.75) yielding}$$

For 30lbs/sf wind load – 90plf:

$$M = w l^2 / 3 = (180 \text{ lb} * (3.5 \text{ ft})^2) / 3 = 735 \text{ lb-ft}$$

$$M_x / M = SF$$

$$1668 \text{ lb-ft} / 735 \text{ lb-ft} = 2.27 > 1.67 \Rightarrow \text{design OK}$$

- CORNER POST EPN-0669

$$S_x = I_x / C_x = 1.339 \text{ in}^4 / 1.819 \text{ in} = 0.736 \text{ in}^3$$

$$S_y = I_y / C_y = 1.339 \text{ in}^4 / 1.819 \text{ in} = 0.736 \text{ in}^3$$

$$M_x = 34.8 \text{ ksi} * 0.736 \text{ in}^3 = 25.61 \text{ kip-in} = 2134 \text{ lb-ft}$$

$$M_y = 34.8 \text{ ksi} * 0.736 \text{ in}^3 = 25.61 \text{ kip-in} = 2134 \text{ lb-ft}$$

- HORIZONTAL INFILL 61106640

$$S_x = I_x / C_x = 0.1090 \text{ in}^4 / 0.438 \text{ in} = 0.249 \text{ in}^3$$

$$S_y = I_y / C_y = 3.1994 \text{ in}^4 / 3.438 \text{ in} = 0.931 \text{ in}^3$$

$$M_x = 6.2 \text{ ksi} * 0.249 \text{ in}^3 = 1.5438 \text{ kip-in} = 128.7 \text{ lb-ft}$$

$$M_y = 6.2 \text{ ksi} * 0.931 \text{ in}^3 = 5.7722 \text{ kip-in} = 481 \text{ lb-ft}$$

For 50lbs distributed load applied horizontally at the middle (slat is 6" wide):

$$M = PL/4 = (25\text{lb} * (68\text{in}/12)^2) / 8 = 37.5\text{lb-ft}$$

$$M_x / M = SF$$

$$128.7 \text{ lb-ft} / 37.5\text{lb-ft} = 3.43 > 1.67 \rightarrow \text{design OK}$$

- DSP INFILL (all styles)

Material Barrette –Polypropylene 10%GF

In accordance with IBC 2018 1607.8.1.2, the infill must be able to resist 50 lbf applied over a 1 ft<sup>2</sup> area. In addition to this design load, loads representing factors of safety of 2.5 (125 lbf) and 4.0 (200lbf) shall be tested.

**Test was performed and indicates that DSP infill meet required strength by IBC 2018 and IRC 2018.**

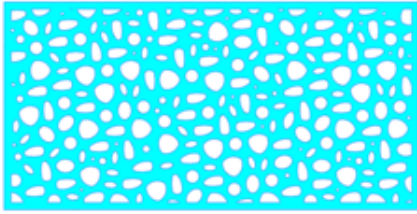

All DSPs - Overall length x overall width = 68" X 34" = 2312 in<sup>2</sup>

"Pebble"

Projected area = 1478 in<sup>2</sup>

Area factor = 1478 in<sup>2</sup> / 2312 in<sup>2</sup>

Area factor = 63.9%



"Boardwalk"

Projected area = 1870 in<sup>2</sup>

Area factor = 1870 in<sup>2</sup> / 2312 in<sup>2</sup>

Area factor = 80.9%



"Optic"

Projected area = 1282 in<sup>2</sup>

Area factor = 1282 in<sup>2</sup> / 2312 in<sup>2</sup>

Area factor = 55.4%

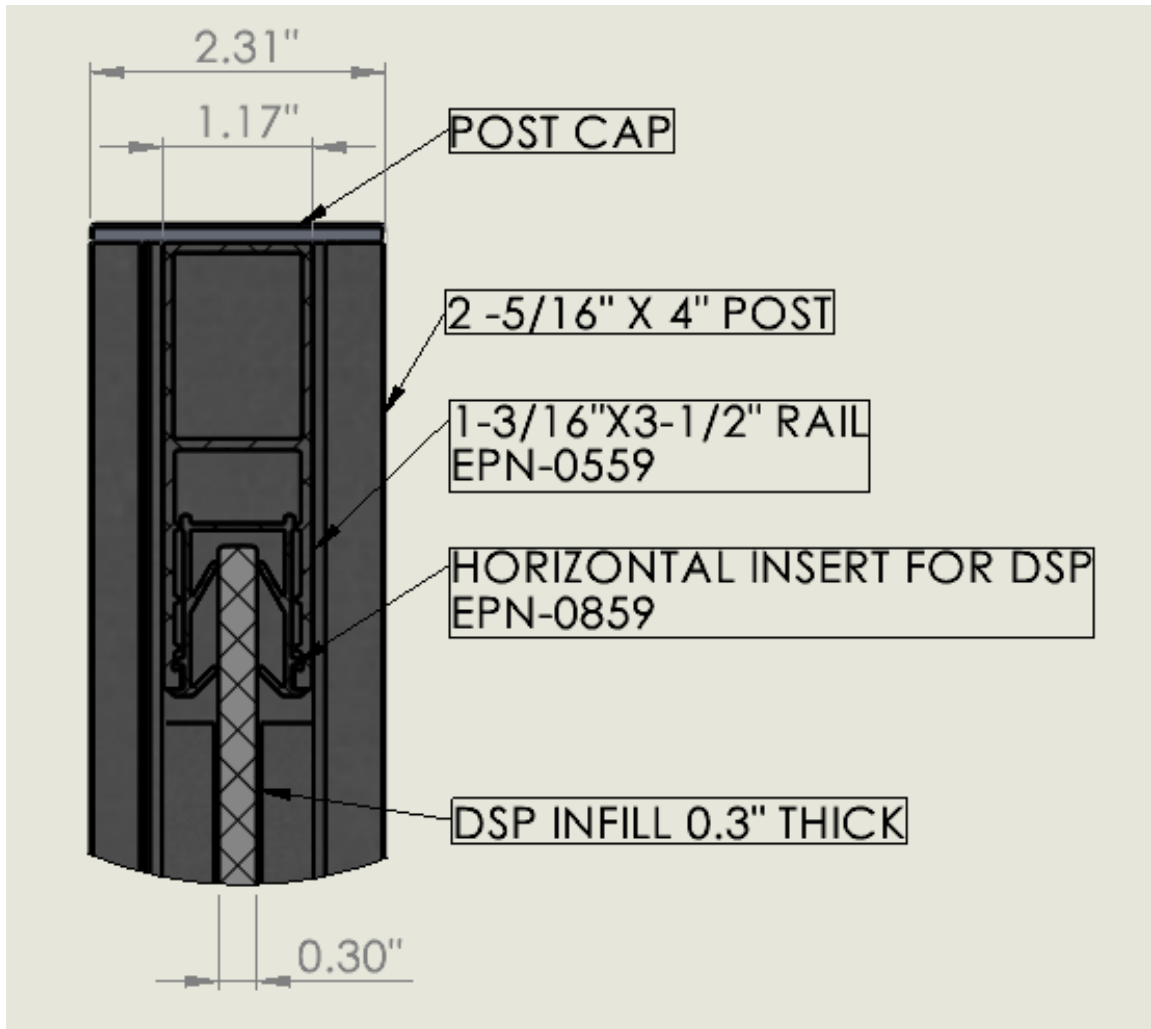

SEE DETAIL ABOVE - INFILL (INSIDE RAIL USING HORIZONTAL INSERT)

#### IV. Result from testing – POST-PLATE connection

##### First Setup:

Mixed material corner post point loaded @ 42" using newly designed 3/8" plate w/current mounting hardware. Loaded to 463lbf when the front two mounting screw threads pulled out of post.

##### Second Setup:

Mixed material corner post point loaded @ 42" using newly designed 3/8" plate w/ current mounting hardware. Loaded to 462lbf when the front two mounting screw threads pulled out of post.

##### Third Setup:

Mixed material end post point loaded @ 42" using newly designed 3/8" plate w/ current mounting hardware. Loaded to 544lbf when the front two mounting screw heads broke.

##### Forth Setup:

Mixed material end post point loaded @ 42" using newly designed 3/8" plate w/ current mounting hardware. Loaded to 526lbf when the front two mounting screw threads pulled out of post.

**The corner post will be omitted in the calculations since is braced in four directions!**

#### V. WIND CALCULATION

- 115MPH wind
- 6ft (68in o.c. posts) wide by 3.5ft high

<b>WIND DESIGN FOR SOLID FENCES</b>			
V (WIND SPEED)	115.00	(MPH)	
Kz (see table 29.3-1)	0.85		
Kd (DIR. FCTR)	0.85		
(EXPOSURE CAT.)	c		
Kzt (TOPO. FCTR)	1.00		
G (GUST EFCT FCTR)	0.85		
E (RATIO OF SOLID TO GROSS AREA)	1.00		
Cf (see fig 29.4-1)	1.45		
qz ( VELOCITY P.) (LB/FT <sup>2</sup> )	24.46		
F (DESIGN WIND FORCE) (LB)	598.29		
FENCE INPUT			
L (LENGTH BETWEEN CL OF POST)	5.67	(FT)	
H (HEIGHT OF FENCE FROM GROUND)	3.50	(FT)	
Af (SOLID AREA NORMAL TO WIND)	19.85	(FT <sup>2</sup> )	
A (GROSS AREA)	19.85	(FT <sup>2</sup> )	
DESIGN WIND FORCE			
DESIGN WIND FORCE	30.15	(LB/FT <sup>2</sup> )	
SHEER FORCE CENTER POST	598.29	(LB)	
SHEER FORCE END POST	299.14	(LB)	
MOMENT AT CENTER POST BASE (FREE TO ROTATE)	1047.01	(FT*LB)	12564.08 (IN*LB)
MOMENT AT END POST BASE (FREE TO ROTATE)	523.50	(FT*LB)	6282.04 (IN*LB)
<b>MOMENT AT CENTER POST BASE (NO ROTATION)</b>	698.00	(FT*LB)	8376.06 (IN*LB)
<b>MOMENT AT END POST BASE (NO ROTATION)</b>	349.00	(FT*LB)	4188.03 (IN*LB)
MAX SHEAR AT END OF CHANNEL	149.57	(LB)	

The maximum allowable Moment at the bottom of the **line post**:

$$M_1 = P * L = ((544 + 526) / 2) * 3.5 \text{ ft} = 1872.5 \text{ lb-ft}$$

From above table, the Moment is  $M_2 = 698 \text{ lb-ft}$

$$M_1 / M_2 = SF$$

$$1872.5 \text{ lb-ft} / 698 \text{ lb-ft} = 2.68 > 1.67 \rightarrow \text{design OK}$$

- 2ft-10in wide (extra post added on standard 6ft (5ft-8in) ) by 6ft high

<b>WIND DESIGN FOR SOLID FENCES</b>			
V (WIND SPEED)	115.00	(MPH)	
Kz (see table 29.3-1)	0.85		
Kd (DIR. FCTR)	0.85		
(EXPOSURE CAT.)	C		
Kzt (TOPO. FCTR)	1.00		
G (GUST EFCT FCTR)	0.85		
E (RATIO OF SOLID TO GROSS AREA)	1.00		
Cf (see fig 29.4-1)	1.45		
qz ( VELOCITY P.) (LB/FT <sup>2</sup> )	24.46		
F (DESIGN WIND FORCE) (LB)	511.92		
<b>FENCE INPUT</b>			
L (LENGTH BETWEEN CL OF POST)	2.83	(FT)	
H (HEIGHT OF FENCE FROM GROUND)	6.00	(FT)	
Af (SOLID AREA NORMAL TO WIND)	16.98	(FT <sup>2</sup> )	
A (GROSS AREA)	16.98	(FT <sup>2</sup> )	
<b>DESIGN WIND FORCE</b>			
DESIGN WIND FORCE	30.15	(LB/FT <sup>2</sup> )	
SHEER FORCE CENTER POST	511.92	(LB)	
SHEER FORCE END POST	255.96	(LB)	
MOMENT AT CENTER POST BASE (FREE TO ROTATE)	1535.75	18428.95	(IN*LB)
MOMENT AT END POST BASE (FREE TO ROTATE)	767.87	9214.48	(IN*LB)
MOMENT AT CENTER POST BASE <b>(NO ROTATION)</b>	1023.83	12285.97	(IN*LB)
MOMENT AT END POST BASE <b>(NO ROTATION)</b>	511.92	6142.98	(IN*LB)
MAX SHEAR AT END OF CHANNEL	127.98	(LB)	

The maximum allowable Moment at the bottom of the **line post**:

$$M_1 = P * L = ((544 + 526) / 2) * 3.5 \text{ ft} = 1872.5 \text{ lb-ft}$$

From above table, the Moment is  $M_2 = 1023.83 \text{ lb-ft}$

$$M_1 / M_2 = \text{SF}$$

$$1872.5 \text{ lb-ft} / 1023.83 \text{ lb-ft} = 1.83 > 1.67 \rightarrow \text{design OK (between 1.75-2.00)}$$

VI. CONCLUSION

- THE REPORT INDICATES THAT RESISTING MOMENT IS GREATER THAN FLEXURE MOMENTS AND MEETS REQUIREMENTS.
- THE IRC 2018 REQUIRED 36" HIGH GUARDRAIL
- THE IBC 2018 REQUIRED 42" HIGH GURDARAIL
- THE CALCULATIONS AND TEST WERE PERFORMED FOR RAIL LOCATED AT 42" – AND IT PASS
- TO MEET GUARDRAIL LOADS AND WIND LOADS – HALF PRIVACY PANEL AND FULL PRIVACY PANEL NEEDS AN EXTRA POSTS FOR CERTAIN PANEL WIDTHS-SEE BELOW TABLES FOR POST SPACING RELATED TO HEIGHT OF THE PANEL

## POST SPACING TABLE

<b>115MPH WIND-EXPOSURE B&amp;C</b>		
HEIGHT OF THE PANEL (in)	RECOMMENDED POST SPACING (O.C.)	GOVERNING LOAD
≤42	6FT ( 68in)	50plf on top rail
48	5FT ( 60in)	50plf on top rail
54	4FT ( 48in)	50plf on top rail
60	3.5 FT ( 42in)	50plf on top rail
66	3FT (34in)	30psf wind
72	3FT (34in)	30psf wind

<b>115MPH WIND-EXPOSURE D</b>		
HEIGHT OF THE PANEL (in)	RECOMMENDED POST SPACING (O.C.)	GOVERNING LOAD
≤42	6FT ( 68in)	50plf on top rail
48	5FT ( 60in)	50plf on top rail
54	4FT ( 48in)	36.5 psf wind
60	3FT (34in)	36.5 psf wind
66	2.5FT (30in)	36.5 psf wind
72	2FT (24in)	36.5 psf wind

<b>120MPH WIND-EXPOSURE B&amp;C</b>		
<b>HEIGHT OF THE PANEL (in)</b>	<b>RECOMMENDED POST SPACING (O.C.)</b>	<b>GOVERNING LOAD</b>
≤42	6FT ( 68in)	50plf on top rail
48	5FT ( 60in)	50plf on top rail
54	4FT ( 48in)	50plf on top rail
60	3.5 FT ( 42in)	32.8 psf wind
66	3FT (34in)	32.8 psf wind
72	2.5FT (30in)	32.8 psf wind

<b>120MPH WIND-EXPOSURE D</b>		
<b>HEIGHT OF THE PANEL (in)</b>	<b>RECOMMENDED POST SPACING (O.C.)</b>	<b>GOVERNING LOAD</b>
≤42	6FT ( 68in)	50plf on top rail
48	4.5FT ( 54in)	39.8 psf wind
54	3.5FT ( 42in)	39.8 psf wind
60	3FT (34in)	39.8 psf wind
66	2.5FT (30in)	39.8 psf wind
72	2FT (24in)	39.8 psf wind

<b>130MPH WIND-EXPOSURE B&amp;C</b>		
<b>HEIGHT OF THE PANEL (in)</b>	<b>RECOMMENDED POST SPACING (O.C.)</b>	<b>GOVERNING LOAD</b>
≤42	6FT ( 68in)	50plf on top rail
48	4.5FT ( 54in)	38.5 psf wind
54	3.5FT ( 42in)	38.5 psf wind
60	3FT (34in)	38.5 psf wind
66	2.5FT (30in)	38.5 psf wind
72	2FT (24in)	38.5 psf wind

<b>130MPH WIND-EXPOSURE D</b>		
<b>HEIGHT OF THE PANEL (in)</b>	<b>RECOMMENDED POST SPACING (O.C.)</b>	<b>GOVERNING LOAD</b>
≤42	5FT ( 60in)	46.7 psf wind
48	4FT ( 48in)	46.7 psf wind
54	3FT ( 34in)	46.7 psf wind
60	2.5FT (30in)	46.7 psf wind
66	2FT (24in)	46.7 psf wind
72	1.67FT (20in)	46.7 psf wind

<b>140MPH WIND-EXPOSURE B&amp;C</b>		
<b>HEIGHT OF THE PANEL (in)</b>	<b>RECOMMENDED POST SPACING (O.C.)</b>	<b>GOVERNING LOAD</b>
≤42	5FT ( 60in)	44.7 psf wind
48	4FT ( 48in)	44.7 psf wind
54	3FT ( 34in)	44.7 psf wind
60	2.5FT (30in)	44.7 psf wind
66	2FT (24in)	44.7 psf wind
72	1.67FT (20in)	44.7 psf wind

<b>140MPH WIND-EXPOSURE D</b>		
<b>HEIGHT OF THE PANEL (in)</b>	<b>RECOMMENDED POST SPACING (O.C.)</b>	<b>GOVERNING LOAD</b>
≤42	4.5FT ( 54in)	54.1 psf wind
48	3FT ( 34in)	54.1 psf wind
54	2.5FT ( 30in)	54.1 psf wind
60	2FT (24in)	54.1 psf wind
66	1.67FT (20in)	54.1 psf wind
72	1.5FT (18in)	54.1 psf wind

\* 6FT is nominal size of the panel, which is 68"

\* 3FT is a distance measured from center of the post to the center of added post 34"

- SUGGESTION TO USE #8 SCREW TO SECURE SLATS IN THE 6FT WIDE SPANS