

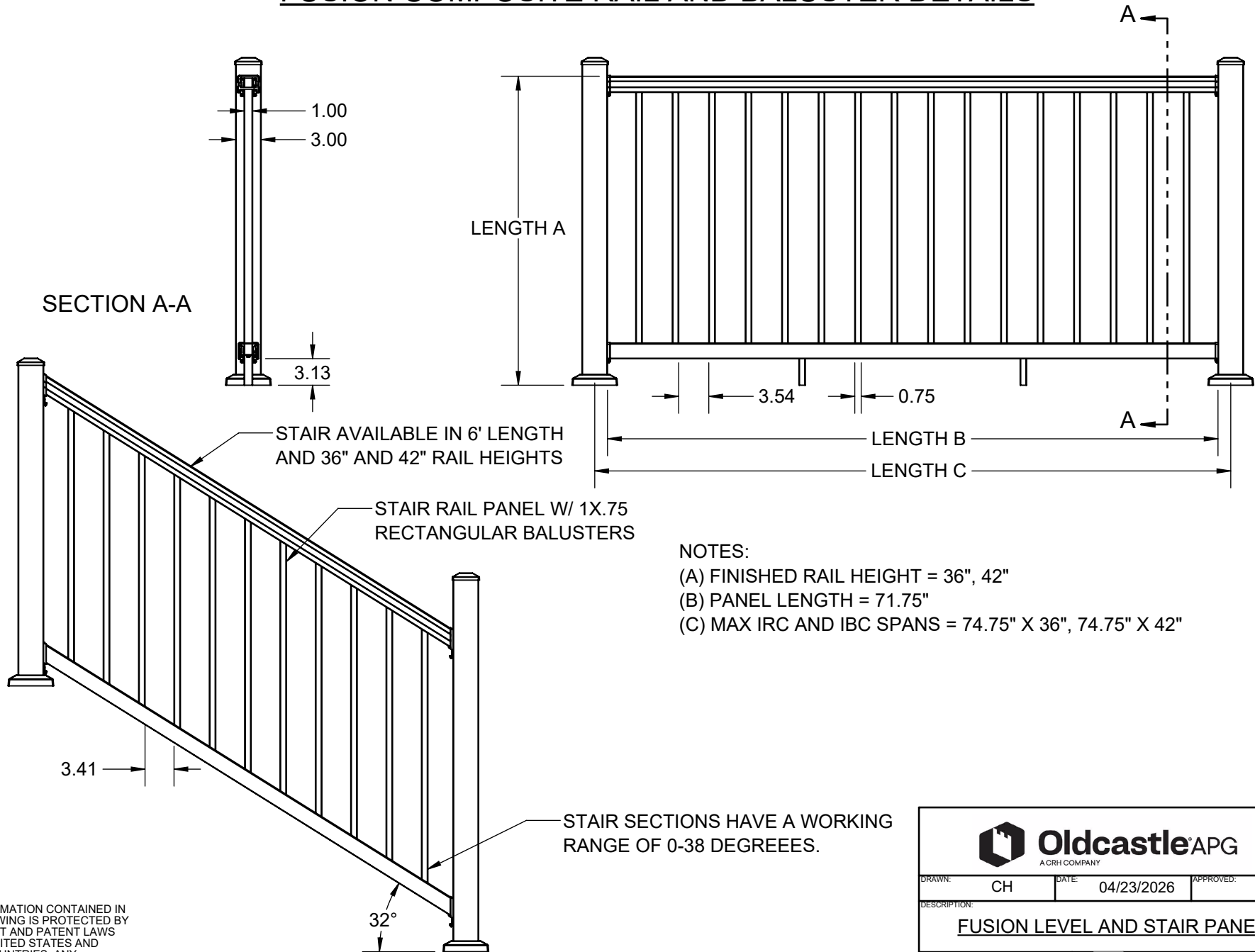

FUSION COMPOSITE RAIL AND BALUSTER DETAILS



THE INFORMATION CONTAINED IN THIS DRAWING IS PROTECTED BY COPYRIGHT AND PATENT LAWS OF THE UNITED STATES AND OTHER COUNTRIES. ANY REPRODUCTION IN PART OR AS A WHOLE WITHOUT WRITTEN PERMISSION IS PROHIBITED.

		
DRAWN: CH	DATE: 04/23/2026	APPROVED:
DESCRIPTION: FUSION LEVEL AND STAIR PANEL		
SHEET 1 OF 8	REVISION	PART NUMBER
SCALE 1:16	0	N/A
WEIGHT: N/A		

TOP AND BOTTOM RAIL

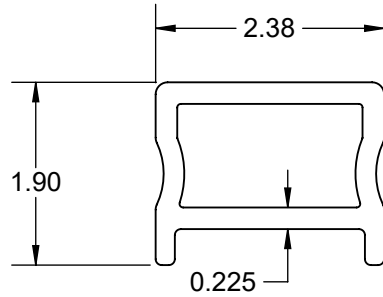

TOP RAIL

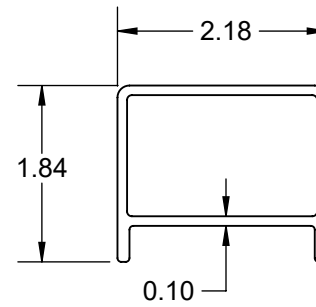

BOTTOM RAIL

POST

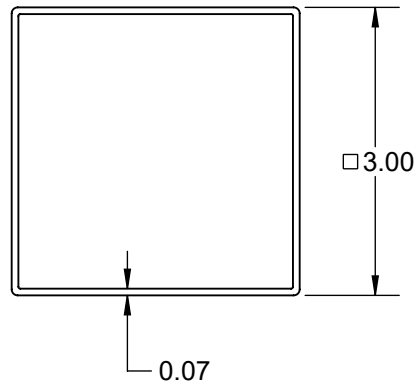

BALUSTER

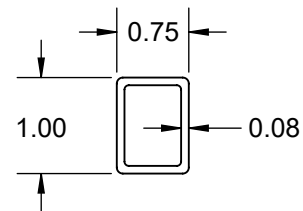

THE INFORMATION CONTAINED IN THIS DRAWING IS PROTECTED BY COPYRIGHT AND PATENT LAWS OF THE UNITED STATES AND OTHER COUNTRIES. ANY REPRODUCTION IN PART OR AS A WHOLE WITHOUT WRITTEN PERMISSION IS PROHIBITED.

 Oldcastle^{APG} <small>ACRH COMPANY</small>		
DRAWN: CH	DATE: 04/23/2026	APPROVED:
DESCRIPTION: FUSION PROFILES		
SHEET 2 OF 8	REVISION	PART NUMBER
SCALE 1:2	0	N/A
WEIGHT: N/A		

FUSION POST AND SURFACE MOUNT DETAIL

POSTS	LENGTH A
3" X 38" FOR 36" RAIL	38"
3" X 44" FOR 42" RAIL	44"
3" X 50" FOR 42" STAIR RAIL	50"

NOTE:
POST KITS INCLUDE 2.77" STEEL POST, 3" VINYL SLEEVE,
2 PIECE TRIM KIT, POST CAP, AND LEVELING SHIMS

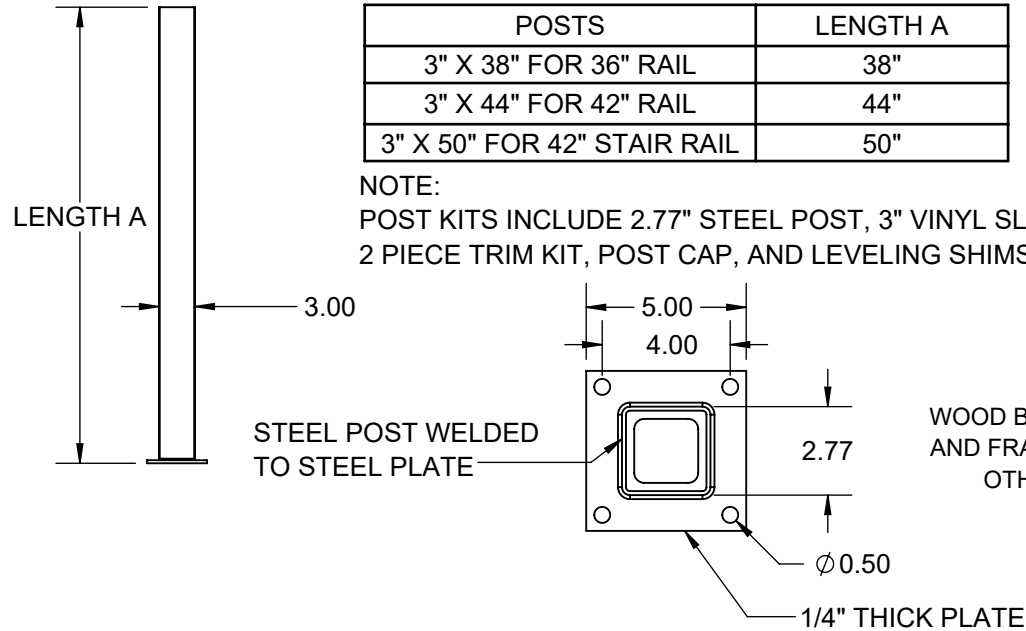

POST BASE CONNECTION INTO WOOD WITH LAG BOLTS

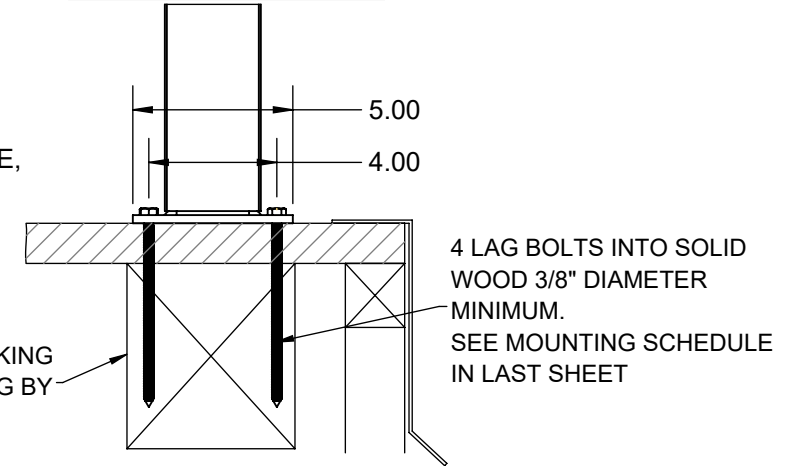

POST BASE CONNECTION INTO CONCRETE WITH WEDGE ANCHORS

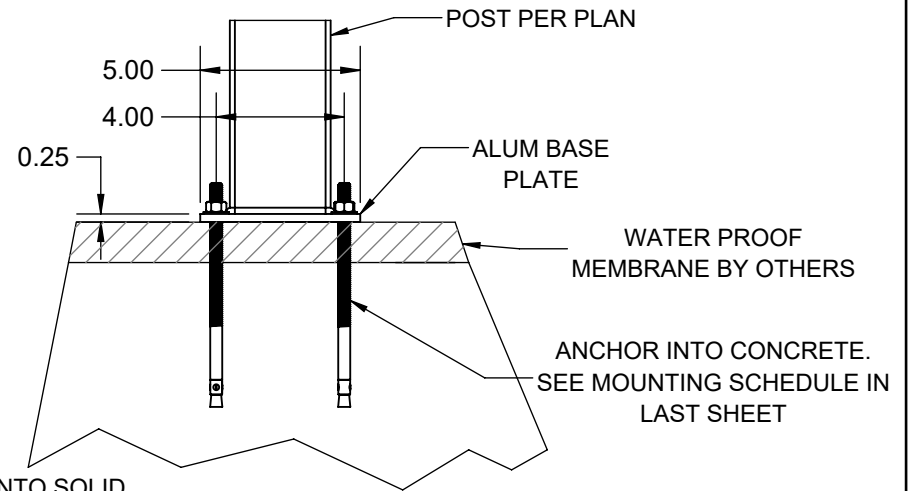

POST BASE CONNECTION INTO WOOD WITH THROUGH BOLTS

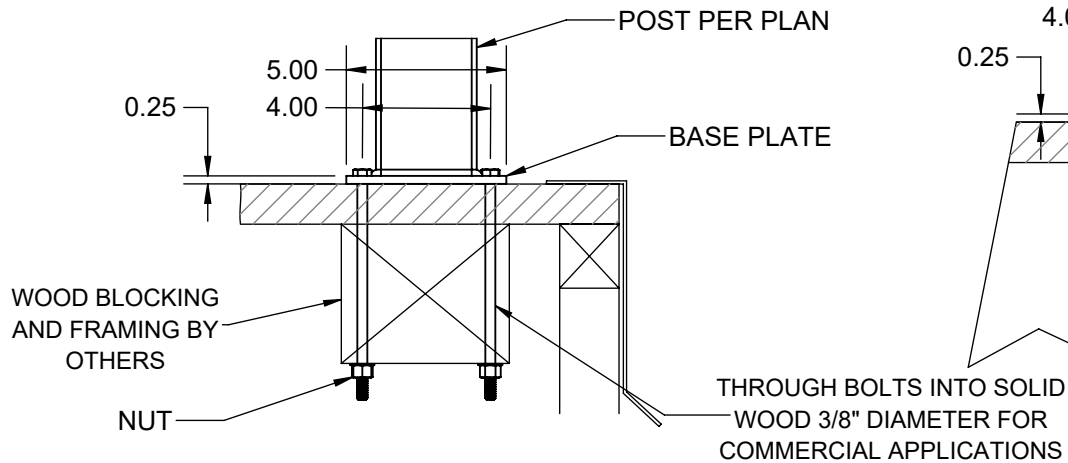

NOTE:

1. COMMERCIAL APPLICATIONS ARE ALWAYS BOLTED, USE 3/8" DIAMETER A307 THROUGH BOLTS INTO SOLID WOOD BLOCKING.
2. WOOD BLOCKING BY OTHERS.
3. BLOCKING MUST BE DESIGNED TO WITHSTAND PROPER LOADING.

THE INFORMATION CONTAINED IN THIS DRAWING IS PROTECTED BY COPYRIGHT AND PATENT LAWS OF THE UNITED STATES AND OTHER COUNTRIES. ANY REPRODUCTION IN PART OR AS A WHOLE WITHOUT WRITTEN PERMISSION IS PROHIBITED.



DRAWN: CH DATE: 04/23/2026 APPROVED:

DESCRIPTION: FUSION POST AND SURFACE MOUNT
DETAIL

SHEET 3 OF 8 REVISION PART NUMBER
SCALE 1:6
WEIGHT: N/A



N/A

FUSION BRACKETS

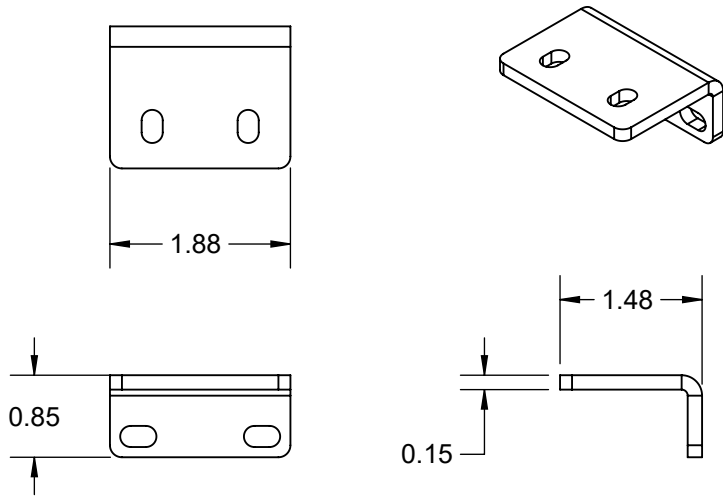

LEVEL BRACKET

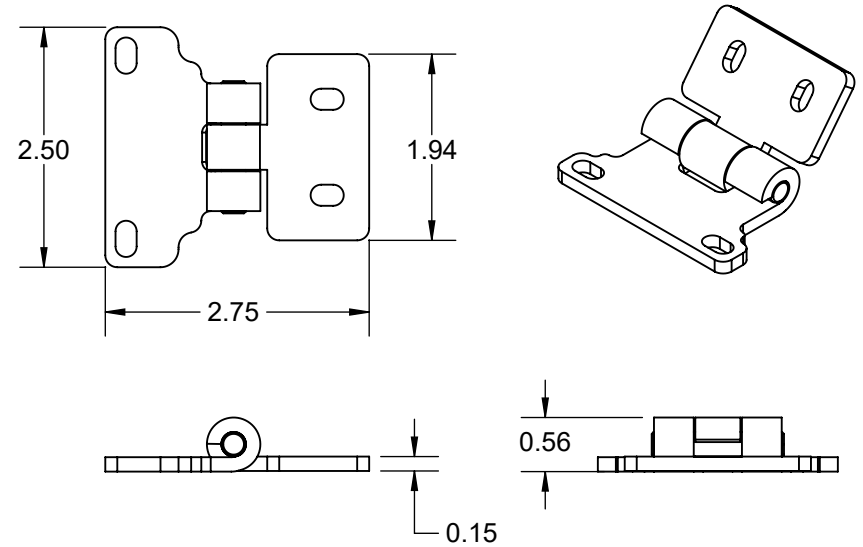

STAIR BRACKET

THE INFORMATION CONTAINED IN THIS DRAWING IS PROTECTED BY COPYRIGHT AND PATENT LAWS OF THE UNITED STATES AND OTHER COUNTRIES. ANY REPRODUCTION IN PART OR AS A WHOLE WITHOUT WRITTEN PERMISSION IS PROHIBITED.

 Oldcastle^{APG} <small>ACRH COMPANY</small>		
DRAWN: CH	DATE: 04/23/2026	APPROVED:
DESCRIPTION: FUSION BRACKETS		
SHEET 4 OF 8	REVISION	PART NUMBER
SCALE 1:2	0	N/A
WEIGHT: N/A		

FUSION ACCESSORIES

LEVEL GASKETS

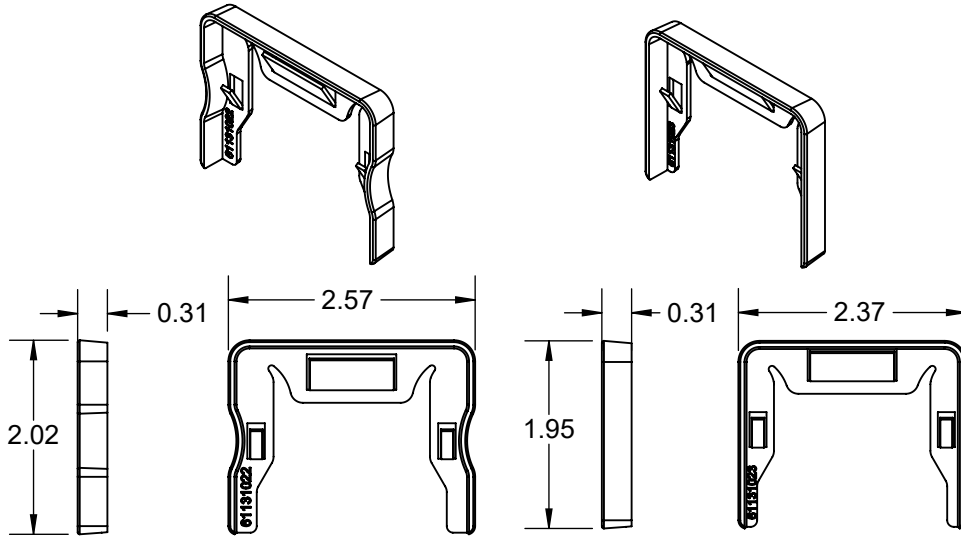

TOP RAIL LEVEL

BOTTOM RAIL LEVEL

STAIR GASKETS

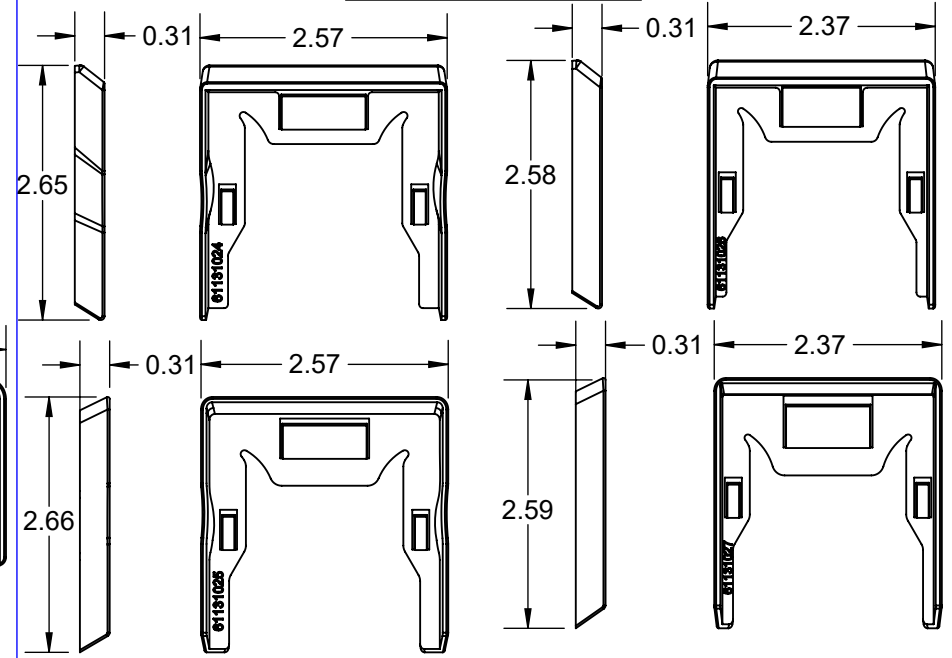

TOP RAIL STAIR

BOTTOM RAIL STAIR

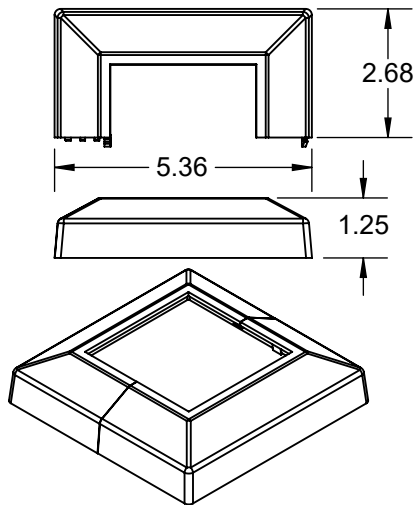

2 PC TRIM RING

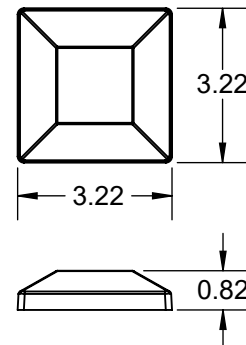

POST CAP

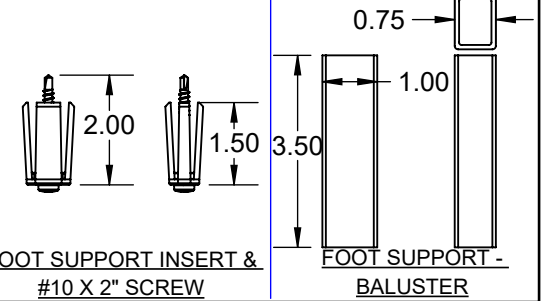

FOOT SUPPORT INSERT & #10 X 2" SCREW

FOOT SUPPORT - BALUSTER

THE INFORMATION CONTAINED IN THIS DRAWING IS PROTECTED BY COPYRIGHT AND PATENT LAWS OF THE UNITED STATES AND OTHER COUNTRIES. ANY REPRODUCTION IN PART OR AS A WHOLE WITHOUT WRITTEN PERMISSION IS PROHIBITED.



DRAWN: CH	DATE: 04/23/2026	APPROVED:
DESCRIPTION: FUSION ACCESSORIES		
SHEET 5 OF 8	REVISION	PART NUMBER
SCALE 1:2	0	N/A
WEIGHT: N/A		

FUSION FASTENER DETAIL

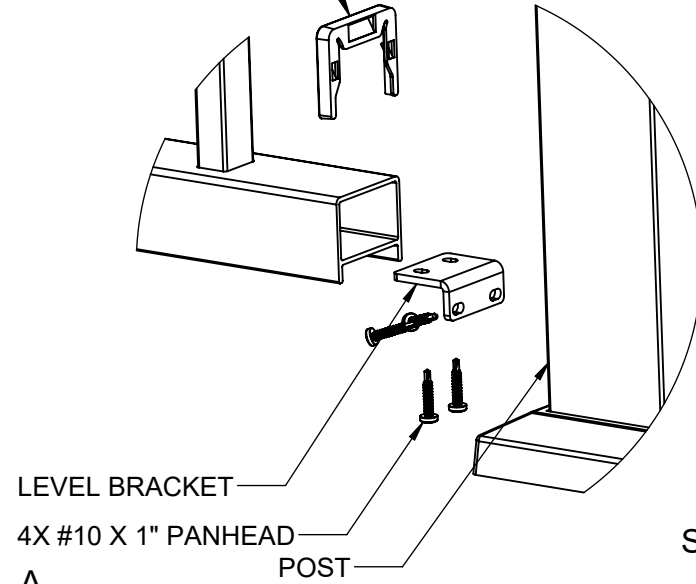
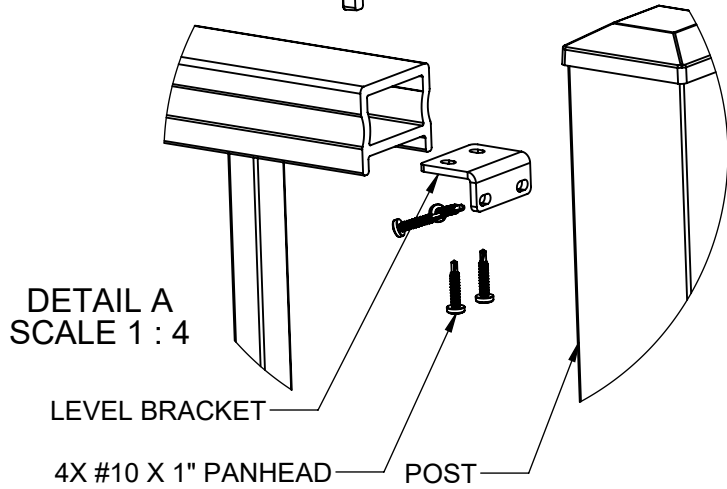
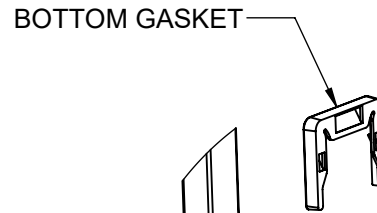
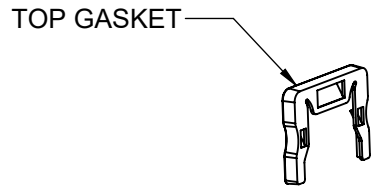

DETAIL A
SCALE 1 : 4

DETAIL B
SCALE 1 : 4

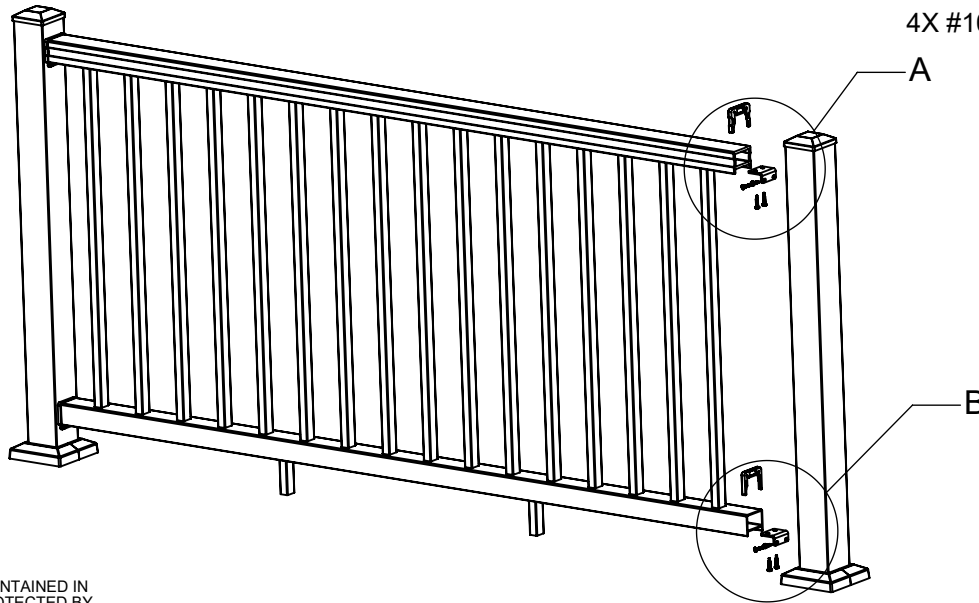

THE INFORMATION CONTAINED IN THIS DRAWING IS PROTECTED BY COPYRIGHT AND PATENT LAWS OF THE UNITED STATES AND OTHER COUNTRIES. ANY REPRODUCTION IN PART OR AS A WHOLE WITHOUT WRITTEN PERMISSION IS PROHIBITED.

Oldcastle^{APG} <small>ACRH COMPANY</small>		
DRAWN: CH	DATE: 04/23/2026	APPROVED:
DESCRIPTION: FUSION FASTENER DETAIL		
SHEET 6 OF 8	REVISION	PART NUMBER
SCALE 1:16	0	N/A
WEIGHT: N/A		

FUSION FASTENER DETAIL

DETAIL A
SCALE 1 : 4

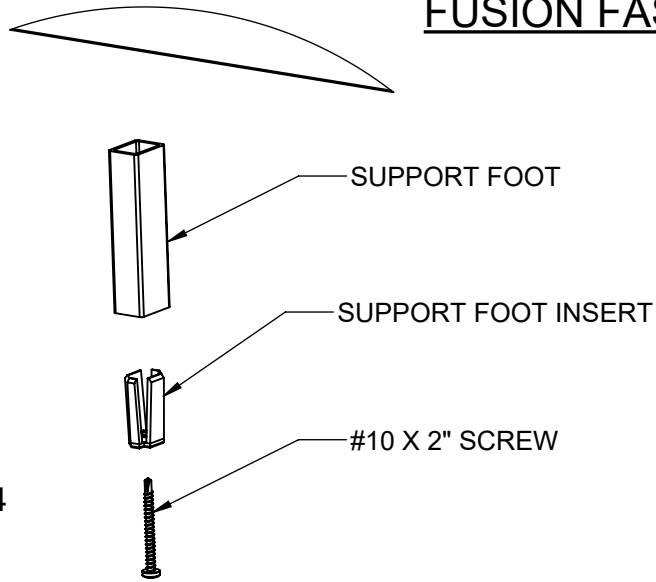

1/2 TRIM RING

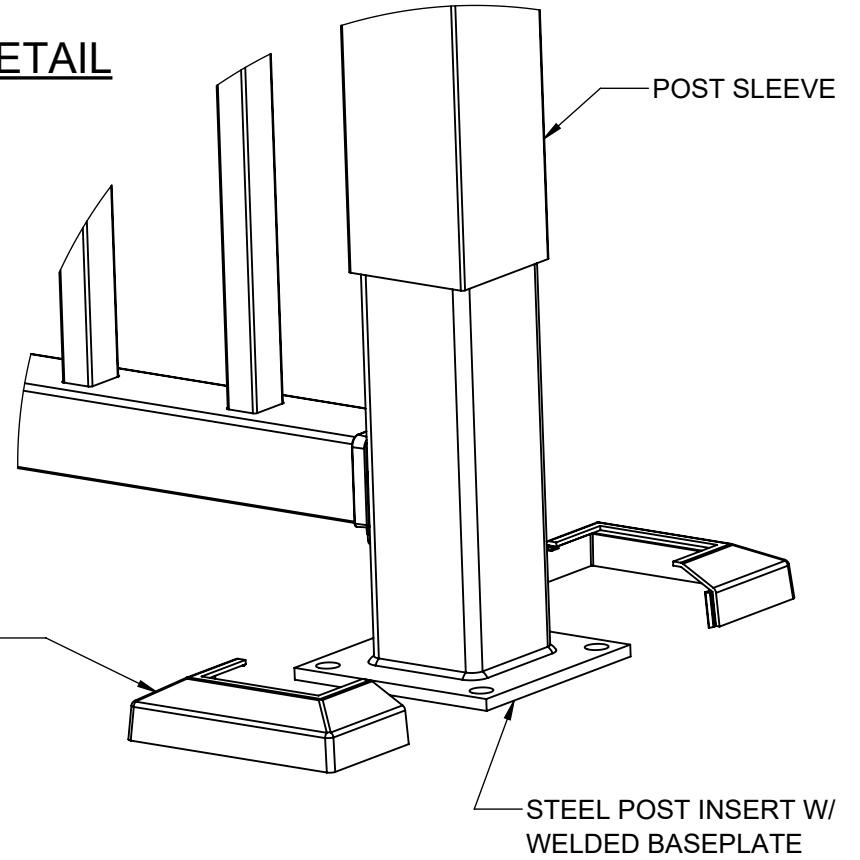

DETAIL B
SCALE 1 : 4

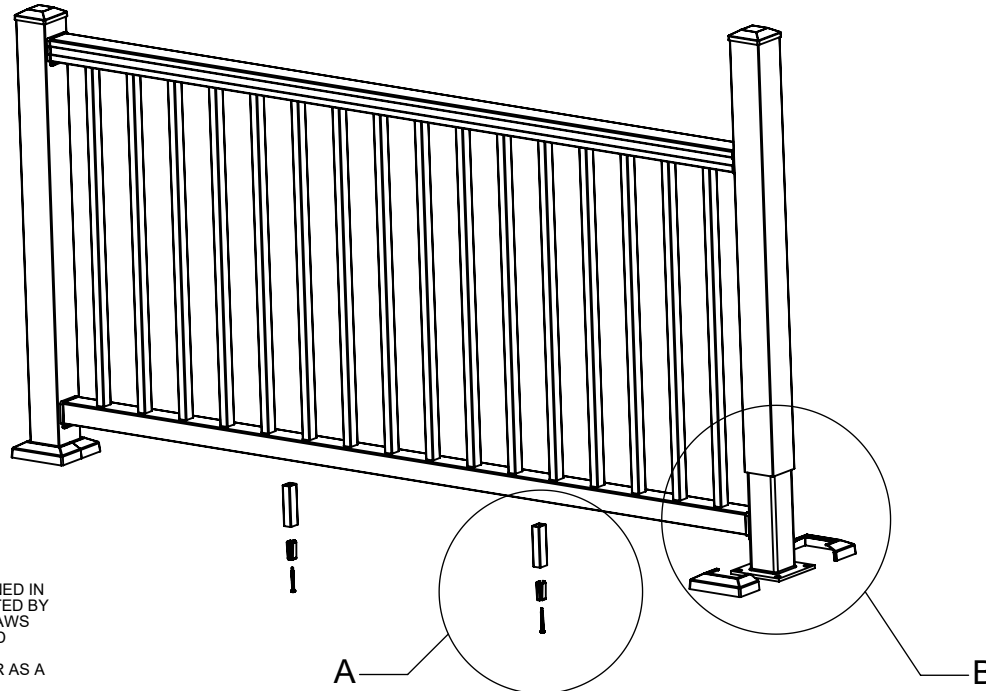

THE INFORMATION CONTAINED IN THIS DRAWING IS PROTECTED BY COPYRIGHT AND PATENT LAWS OF THE UNITED STATES AND OTHER COUNTRIES. ANY REPRODUCTION IN PART OR AS A WHOLE WITHOUT WRITTEN PERMISSION IS PROHIBITED.

		
DRAWN: CH	DATE: 04/23/2026	APPROVED:
DESCRIPTION: FUSION FASTENER DETAIL		
SHEET 7 OF 8	REVISION	PART NUMBER
SCALE 1:16	0	N/A
WEIGHT: N/A		

MOUNTING SCHEDULE

FOR RESIDENTIAL APPLICATIONS 36" HIGH					
PANEL WIDTH	LOAD	RECOMMENDED BOLT APPLICATION	FOR LAG BOLT APPLICATION 3/8" DIA. SCREW. MINIMUM EMBEDDED SCREW THREAD LENGTH REQUIRED	FOR THROUGH BOLT APPLICATION	FOR CONCRETE ANCHOR APPLICATION 3/8" TITAN HD ANCHOR MINIMUM REQUIRED LENGTH (MINIMUM DISTANCE OF 4" FROM EDGE REQUIRED)
6FT	200LBS	LAG BOLT -OR- THROUGH BOLT -OR- CONCRETE ANCHOR	3IN	3/8" HEX BOLT 3/8" FLAT WASHER 3/8" LOCK WASHER 3/8" NUT	3IN
4FT			2.5IN		3IN

FOR COMMERCIAL APPLICATIONS 42" HIGH					
PANEL WIDTH	LOAD	RECOMMENDED BOLT APPLICATION	FOR LAG BOLT APPLICATION 3/8" DIA. SCREW. MINIMUM EMBEDDED SCREW THREAD LENGTH REQUIRED	FOR THROUGH BOLT APPLICATION	FOR CONCRETE ANCHOR APPLICATION 3/8" TITAN HD ANCHOR MINIMUM REQUIRED LENGTH (MINIMUM DISTANCE OF 4" FROM EDGE REQUIRED)
6FT	300LBS	LAG BOLT -OR- THROUGH BOLT -OR- CONCRETE ANCHOR	3IN	3/8" HEX BOLT 3/8" FLAT WASHER 3/8" LOCK WASHER 3/8" NUT	3IN
4FT	200LBS		2.5IN		3IN

THE INFORMATION CONTAINED IN THIS DRAWING IS PROTECTED BY COPYRIGHT AND PATENT LAWS OF THE UNITED STATES AND OTHER COUNTRIES. ANY REPRODUCTION IN PART OR AS A WHOLE WITHOUT WRITTEN PERMISSION IS PROHIBITED.

		
DRAWN: CH	DATE: 04/23/2026	APPROVED:
DESCRIPTION: FUSION MOUNTING SCHEDULE		
SHEET 8 OF 8	REVISION	PART NUMBER
SCALE 1:16	0	N/A
WEIGHT: N/A		