

FINYL LINE T-TOP LEVEL AND STAIR RAIL DETAILS

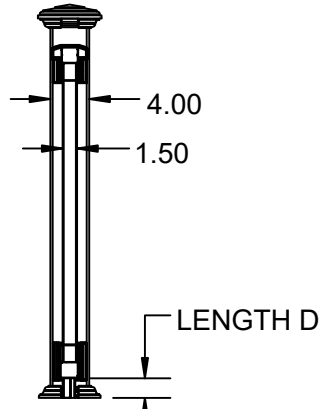

SECTION Z-Z

STAIR AVAILABLE IN
6' AND 8' LENGTHS,
36" AND 42" RAIL HEIGHTS

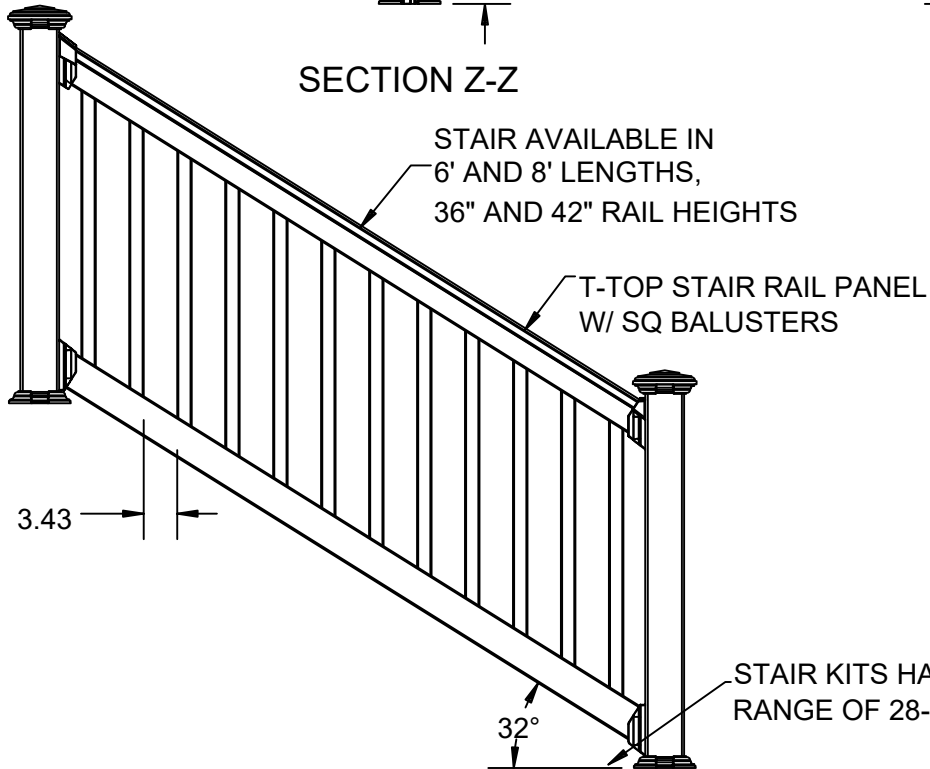

STAIR KITS HAVE A WORKING
RANGE OF 28-38 DEGREES.

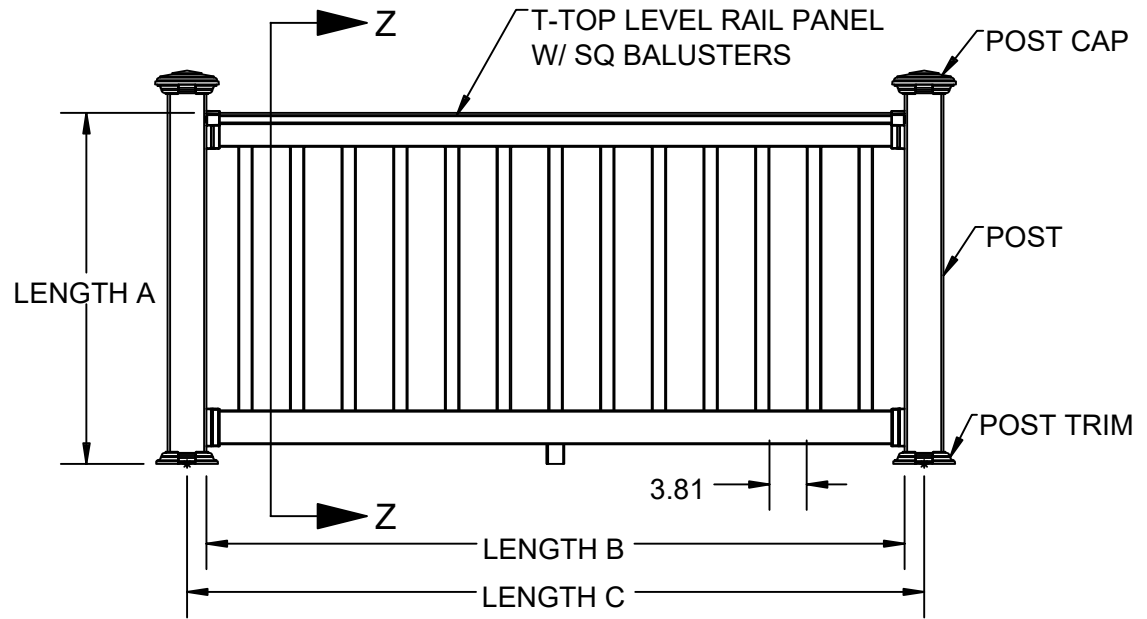

- NOTE:
 (A) FINISHED RAIL HEIGHT = 36", 42"
 (B) PANEL LENGTH = 47.75", 59.75", 71.75", 95.75", 119.75"
 (C) MAX SPANS = 120X36" IRC, 96X42" IBC
 (D) BOTTOM SPACE = 2"

THE INFORMATION CONTAINED IN THIS DRAWING IS PROTECTED BY COPYRIGHT AND PATENT LAWS OF THE UNITED STATES AND OTHER COUNTRIES. ANY REPRODUCTION IN PART OR AS A WHOLE WITHOUT WRITTEN PERMISSION IS PROHIBITED.

1	CMJ	3/11/2022	N/A	ADDED FINYL T-TOP DSP DETAIL SHEET
REV BY		DATE	PCR	DESCRIPTION

DRAWN: TB	DATE: 11/19/2021	APPROVED: CH	
DESCRIPTION: FINYL LINE T-TOP LEVEL AND STAIR RAIL			
SHEET 1 OF 6	REVISION	PART NUMBER	
SCALE 1:21		N/A	
WEIGHT: N/A			

FINYL LINE DECK TOP LEVEL AND STAIR RAIL DETAILS

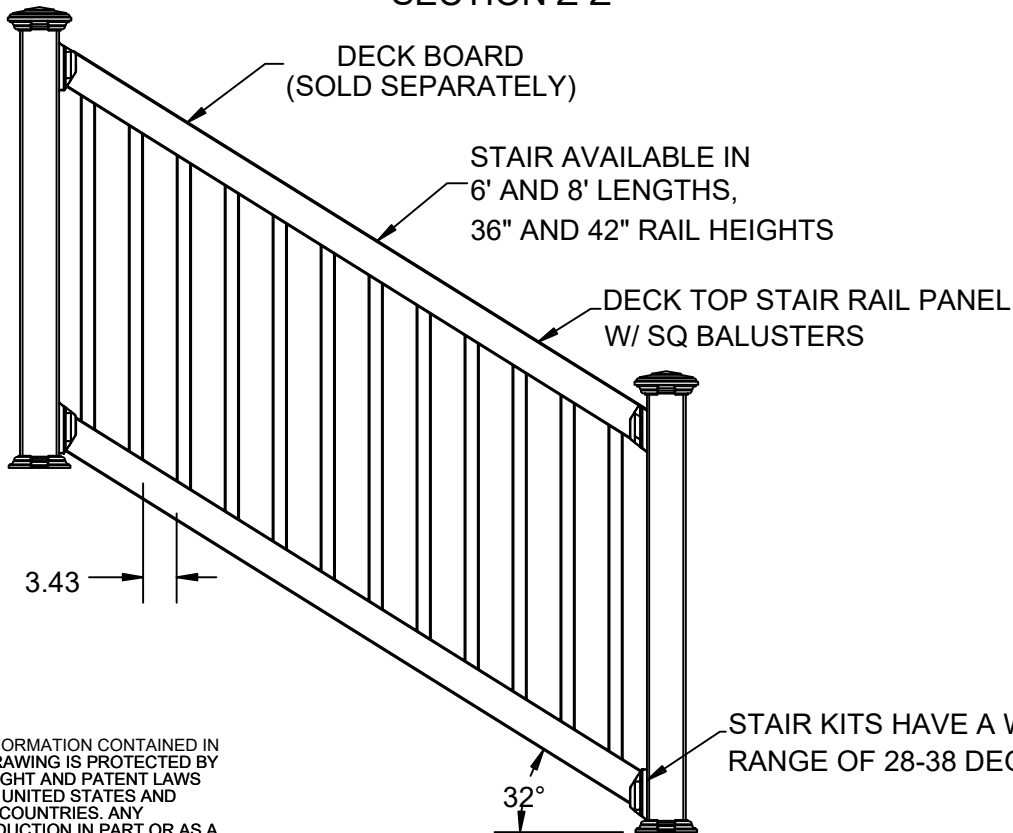
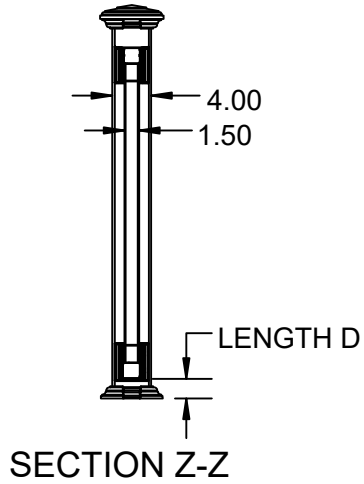
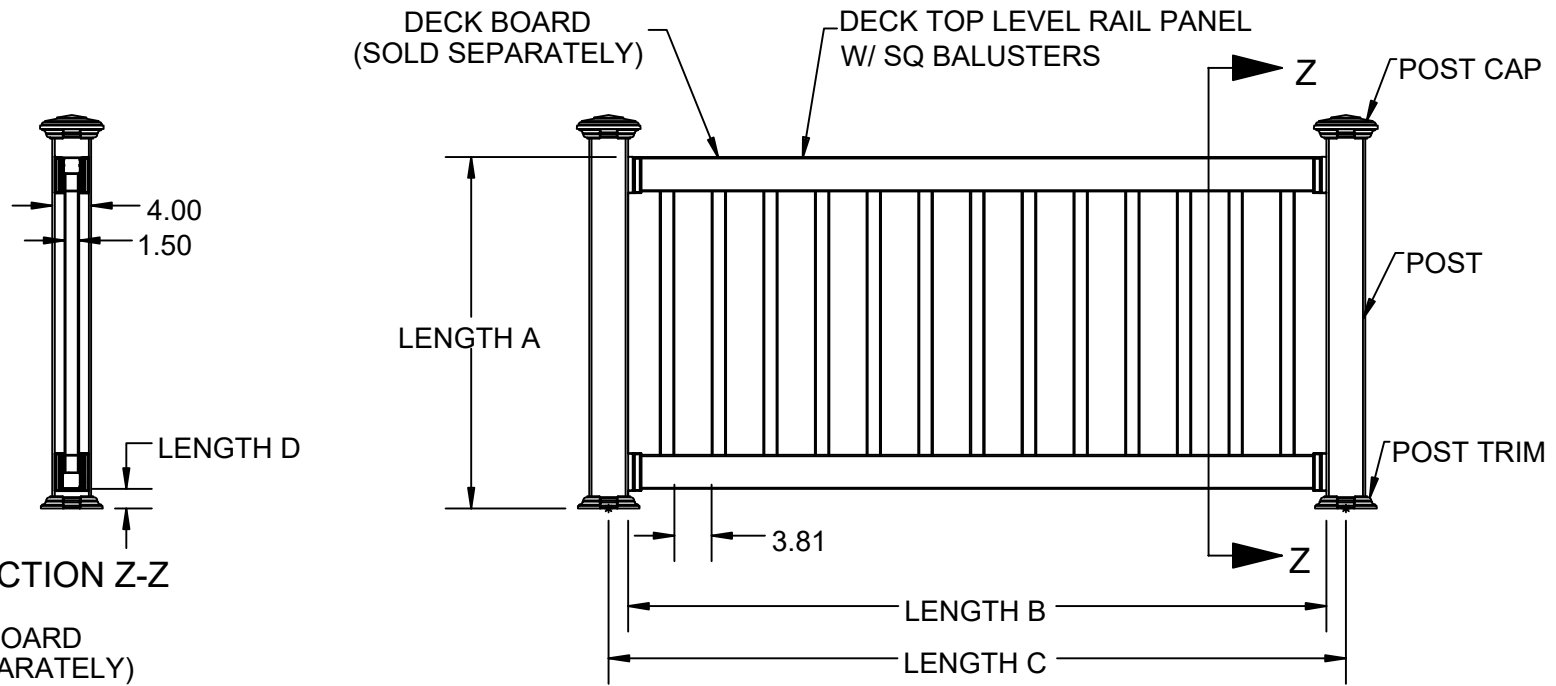

- NOTE:**
 (A) FINISHED RAIL HEIGHT (TOP OF RAIL TO FLOOR) = 36", 42"
 (B) PANEL LENGTH = 47.75", 59.75", 71.75", 95.75", 119.75"
 (C) MAX SPANS = 120X36" IRC, 96X42" IBC
 (D) BOTTOM SPACE = 2"

THE INFORMATION CONTAINED IN THIS DRAWING IS PROTECTED BY COPYRIGHT AND PATENT LAWS OF THE UNITED STATES AND OTHER COUNTRIES. ANY REPRODUCTION IN PART OR AS A WHOLE WITHOUT WRITTEN PERMISSION IS PROHIBITED.

DRAWN:	TB	DATE:	11/19/2021
		APPROVED:	CH
DESCRIPTION: FINYL LINE DECK TOP LEVEL AND STAIR RAIL			
SHEET 2 OF 6		REVISION	PART NUMBER
SCALE 1:21			N/A
WEIGHT: N/A			

FINYL T-TOP DSP LEVEL RAIL DETAIL

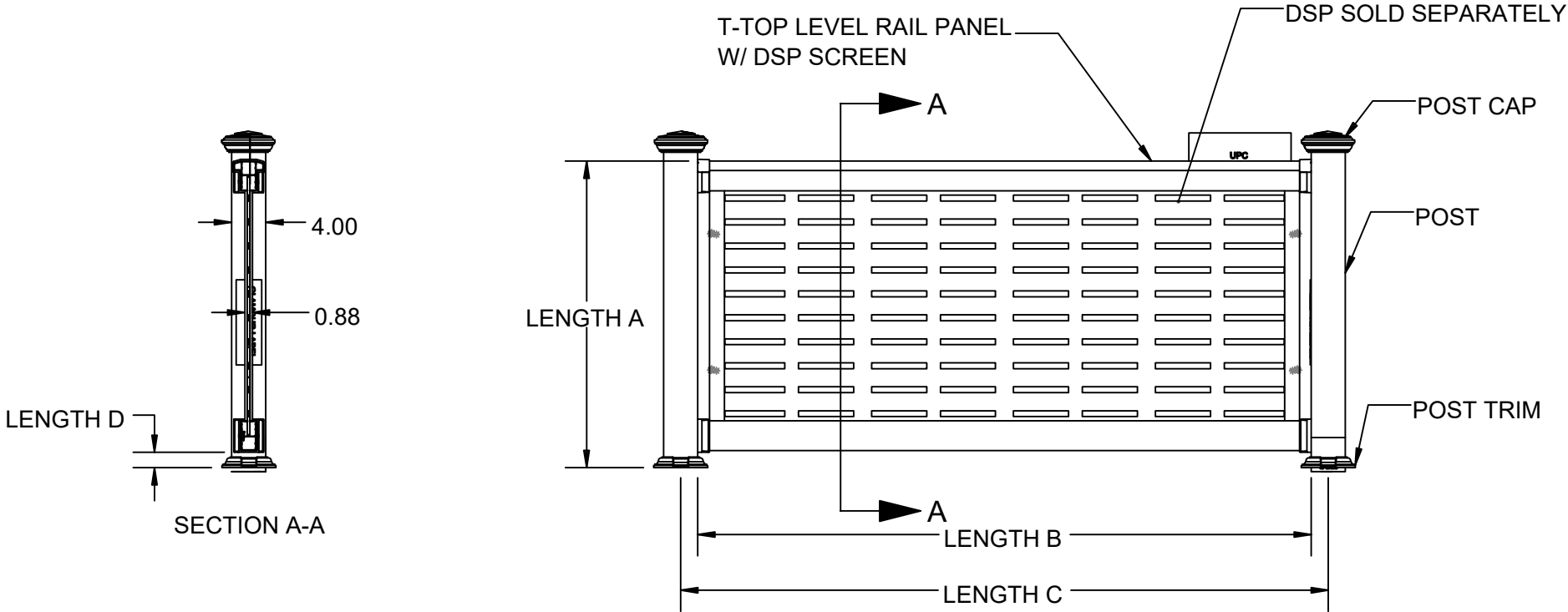

- NOTES:
 (A) FINISHED RAIL HEIGHT (TOP OF RAIL TO FLOOR) = 36"
 (B) PANEL LENGTH = 71.75"
 (C) MAX SPANS = 76" x 36" IRC
 (D) BOTTOM SPACE = 2"

			
DRAWN:	TB	DATE:	11/19/2021
		APPROVED:	CH
DESCRIPTION: FINYL T-TOP LEVEL RAIL			
SHEET 3 OF 6	REVISION	PART NUMBER	
SCALE 1:20	1	N/A	
WEIGHT: 171.18			

THE INFORMATION CONTAINED IN THIS DRAWING IS PROTECTED BY COPYRIGHT AND PATENT LAWS OF THE UNITED STATES AND OTHER COUNTRIES. ANY REPRODUCTION IN PART OR AS A WHOLE WITHOUT WRITTEN PERMISSION IS PROHIBITED.

TOP AND BOTTOM RAIL

NOTE: STIFFENER SELECTION DEPENDS ON SPAN OF SELECTION. SEE PFS TECO RESEARCH REPORT 0112

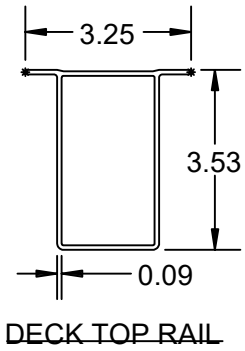

DECK TOP RAIL

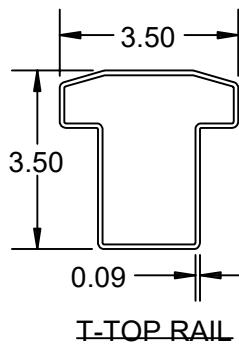

T-TOP RAIL

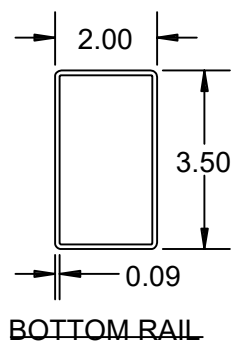

BOTTOM RAIL

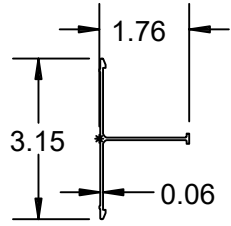

BOTTOM RAIL STIFFENER

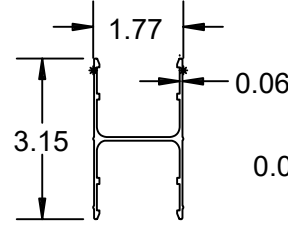

TOP RAIL STIFFENER

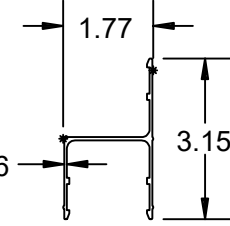

BOTTOM RAIL STIFFENER

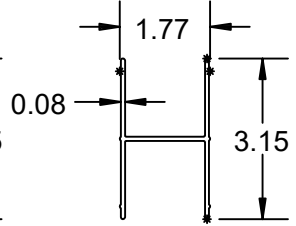

HEAVY TOP RAIL STIFFENER

SEE CODE DOC

POST COMPONENTS

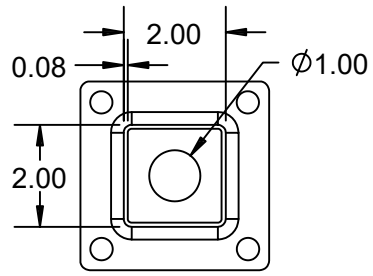

STRUCTURAL POST (RESIDENTIAL)

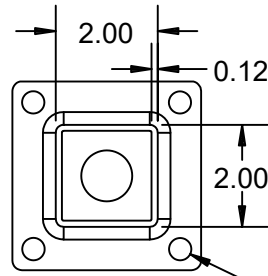

STRUCTURAL POST (COMMERCIAL)

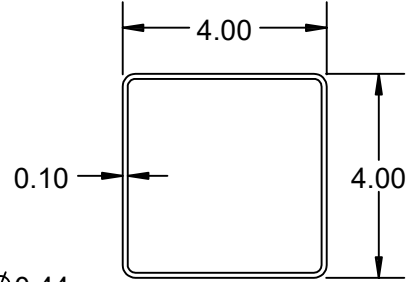

SQ POST SLEEVE

BALUSTERS

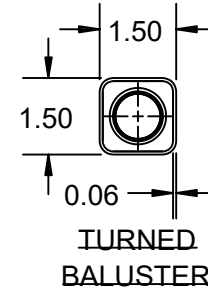

TURNED BALUSTER

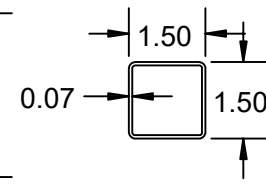

SQ BALUSTER

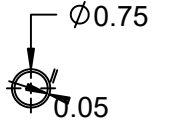

ROUND BALUSTER

THE INFORMATION CONTAINED IN THIS DRAWING IS PROTECTED BY COPYRIGHT AND PATENT LAWS OF THE UNITED STATES AND OTHER COUNTRIES. ANY REPRODUCTION IN PART OR AS A WHOLE WITHOUT WRITTEN PERMISSION IS PROHIBITED.



DRAWN: TB DATE: 11/19/2021 APPROVED: CH

DESCRIPTION: FINYL LINE PROFILE DETAILS

SHEET 4 OF 6
SCALE 1:4
WEIGHT: N/A



REVISION PART NUMBER
N/A

FINYL LINE POST AND MOUNT DETAILS

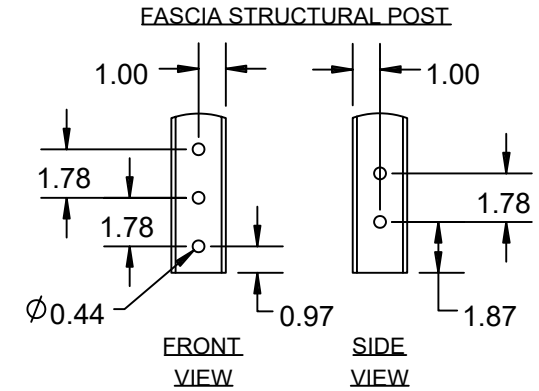
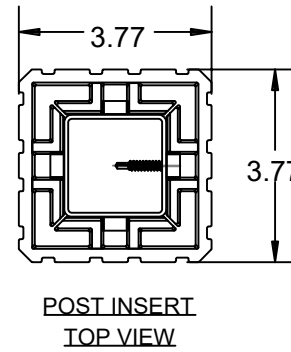
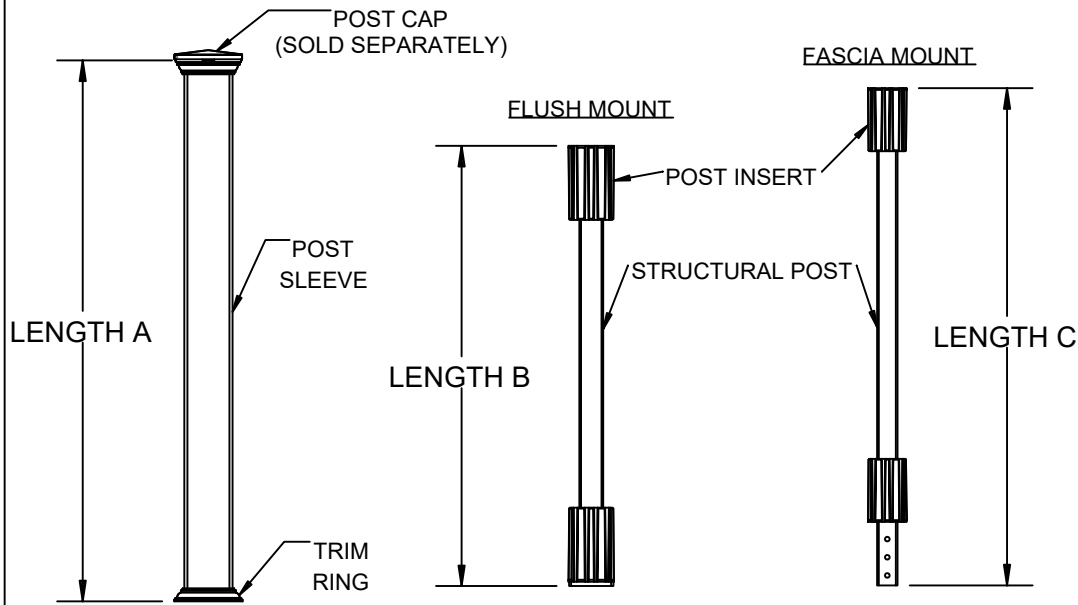

NOTE:
 (A) = 39", 45", 54", 100", 108", 120"
 (B) = 36.625", 42.625"
 (C) = 42.625", 48.625"

POST BASE CONNECTION INTO CONCRETE W/ WEDGE ANCHORS

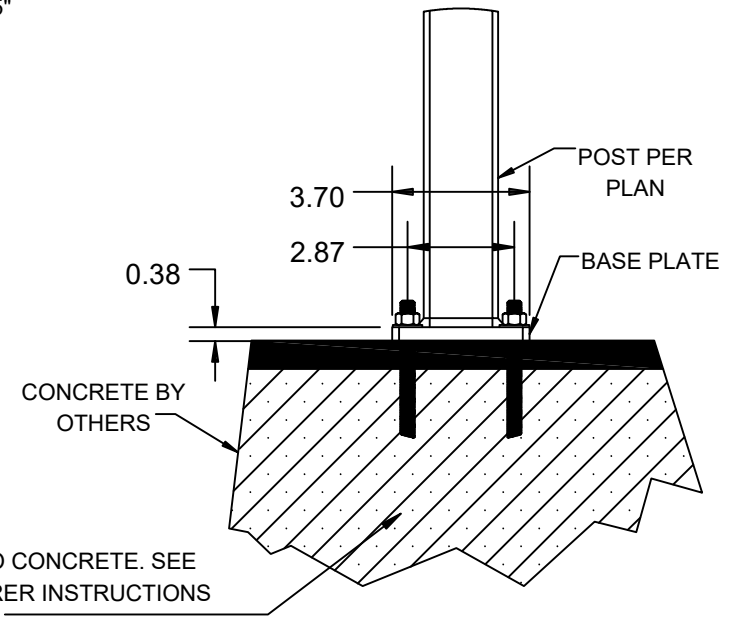
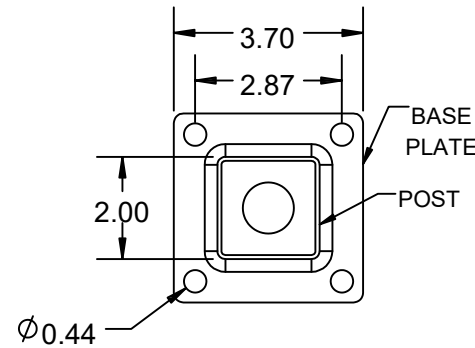
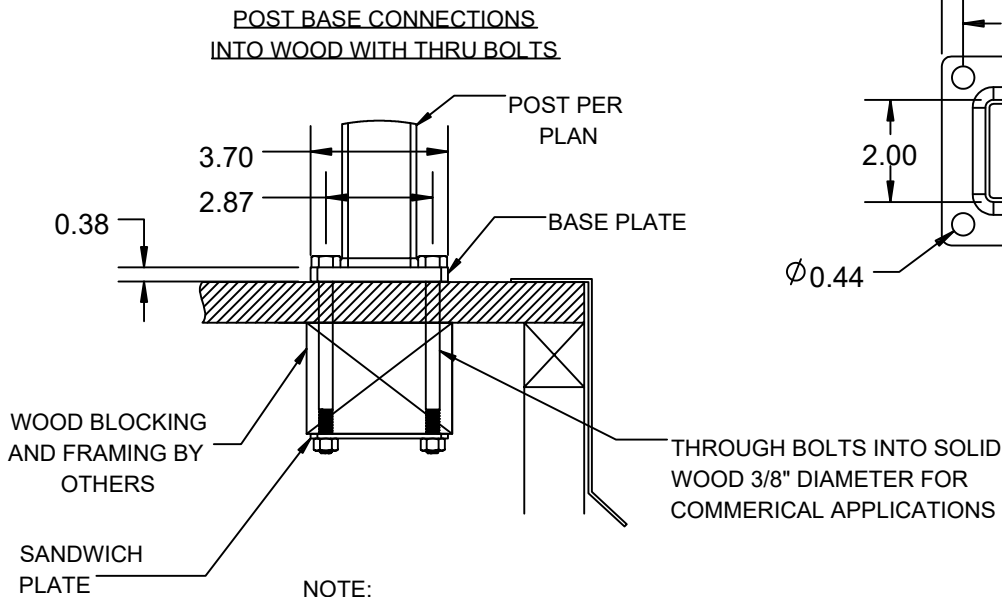

NOTE:
 1. COMMERCIAL APPLICATIONS ARE ALWAYS BOLTED, USE 3/8" DIAMETER A307 THROUGH BOLTS (MIN 5" LENGTH) INTO SOLID WOOD BLOCKING (MIN 4" EMBEDMENT DEPTH).
 2. WOOD BLOCKING BY OTHERS.
 3. BLOCKING MUST BE DESIGNED TO WITHSTAND PROPER LOADING.

THE INFORMATION CONTAINED IN THIS DRAWING IS PROTECTED BY COPYRIGHT AND PATENT LAWS OF THE UNITED STATES AND OTHER COUNTRIES. ANY REPRODUCTION IN PART OR AS A WHOLE WITHOUT WRITTEN PERMISSION IS PROHIBITED.

TOLERANCES							
FRACTION ±	/16	DRAWN:	TB	DATE:	6/7/2021	APPROVED:	CH
XX	±0.01	DESCRIPTION: FINYL LINE POST & MOUNT DETAILS					
XXX	±0.005	SHEET 5 OF 6					
ANGLE	±1.0°	SCALE 1:15					
FINISH	125 RMS	WEIGHT: N/A					
UNLESS OTHERWISE SPECIFIED				PART NUMBER N/A			

FINYL LINE T-TOP DECORATIVE INFILL LEVEL RAIL DETAIL

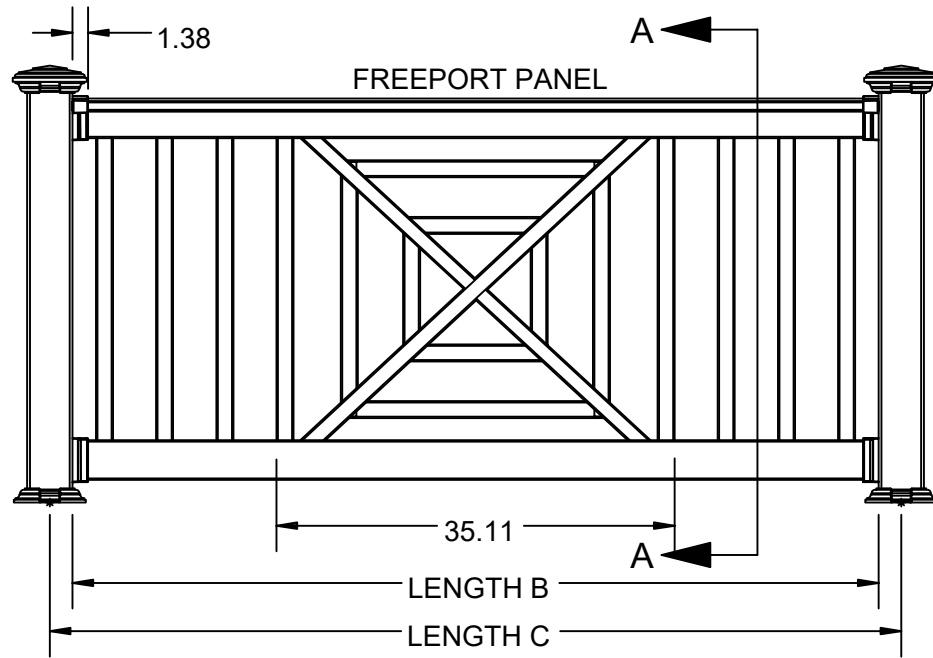

MINIMUM PANEL WIDTH: $35.11 + 2(1.38) = 37.87$

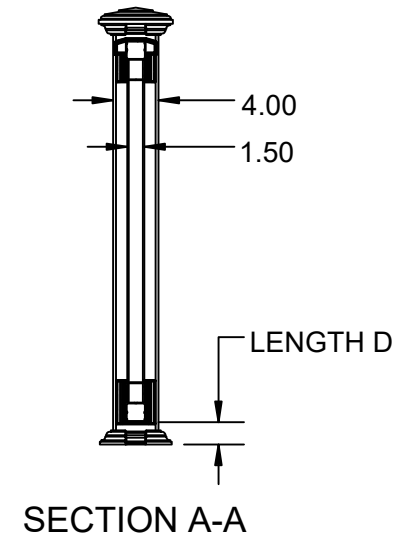

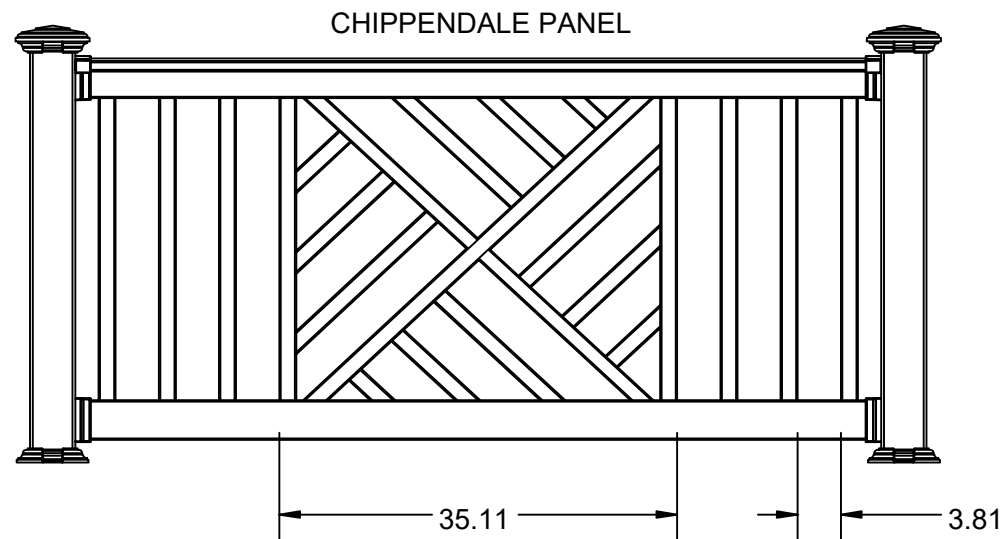

SECTION A-A



MINIMUM PANEL WIDTH: $35.11 + 2(1.38) = 37.87$

NOTE:

- (A) FINISHED RAIL HEIGHT = 36"
- (B) PANEL LENGTH = 71.75", 95.75", 119.75"
- (C) MAX SPANS = 117.25" X 36" IRC
- (D) BOTTOM SPACE = 2"

TOLERANCES				
FRACTION ± 1/16	±0.01	DRAWN: TB	DATE: 11/19/2021	APPROVED: CH
XX	±0.01	DESCRIPTION: FINYL LINE T-TOP DECORATIVE INFILL		
XXX	±0.005	SHEET 6 OF 6		
ANGLE	±1.0°	SCALE 1:15		
FINISH	125 RMS	WEIGHT: N/A		
UNLESS OTHERWISE SPECIFIED				PART NUMBER: N/A

THE INFORMATION CONTAINED IN THIS DRAWING IS PROTECTED BY COPYRIGHT AND PATENT LAWS OF THE UNITED STATES AND OTHER COUNTRIES. ANY REPRODUCTION IN PART OR AS A WHOLE WITHOUT WRITTEN PERMISSION IS PROHIBITED.